

DETAIL - A

| ITEM | PART # | QTY | DESCRIPTION | LENGTH | FINISH | UNIT WT |
|------|---------------|-----|--|--------|---------|---------|
| 1 | AM1004.01 | 6 | V-FRAME WELDMENT | | HDG | 46.58 |
| 2 | AM1004.07 | 6 | 1/2" PLATE | | BARE | 7.39 |
| 3 | AM1004.08 | 6 | 3/8 PLATE | | BARE | 8.91 |
| 4 | AM1028-U.02 | 6 | 3/8" PLATE | | HDG | 12.65 |
| 5 | AM1030-23M.02 | 3 | STIFF ARM HALF CLAMP WELDMENT | | HDG | 0.92 |
| 6 | AM1030-23M.03 | 3 | 1/4" PLATE | | SEE W/O | 0.58 |
| 7 | AM1031.03 | 6 | 1/4" PLATE | | HDG | 1.79 |
| 8 | M1236-3.01 | 6 | UNIV. 12" TO 36" OD RING MOUNT WELDMENT | | HDG | 38.96 |
| 9 | MCMX.04 | 3 | CHAIN MOUNT CLEVIS BOLT ATTACHMENT | | HDG | 1.39 |
| 10 | P178-84 | 3 | 1 1/2" STD PIPE | 7' | HDG | 19.04 |
| 11 | P23-126 | 6 | 2" STD PIPE | 10'-6" | HDG | 38.40 |
| 12 | 27-5580-005 | 12 | 3/4" x 28" B7 HDG ALL-THREAD | 2'-4" | | 3.51 |
| 13 | 27-5481-005 | 24 | 3/4 A36 HDG FLAT WASHER | | | 0.11 |
| 14 | 27-5490-005 | 24 | 3/4 HDG LOCK WASHER | | | 0.04 |
| 15 | 27-5500-005 | 24 | 3/4 HDG HEAVY HEX NUT | | | 0.21 |
| 16 | 27-4403-005 | 24 | 5/8 x 2 GR.5 HDG BOLT | | | 0.27 |
| 17 | 27-4402-005 | 3 | 5/8" x 1 3/4" GR.5 HDG BOLT | | | 0.25 |
| 18 | 27-5370-005 | 30 | 5/8 A36 HDG FLAT WASHER | | | 0.08 |
| 19 | 27-5380-005 | 27 | 5/8 HDG LOCK WASHER | | | 0.03 |
| 20 | 27-5391-005 | 27 | 5/8" HDG HEX NUT | | | 0.08 |
| 21 | 27-4310-005 | 6 | GALV. 1/2" x 4" GR.5 FULL THREADED BOLT | | | 0.27 |
| 22 | 27-4303-005 | 48 | 1/2" x 2" GR.5 HDG BOLT | | | 0.16 |
| 23 | 27-4301-005 | 3 | 1/2" x 1 1/2" GR.5 HDG BOLT | | | 0.13 |
| 24 | 27-4300-005 | 3 | 1/2" x 1 1/4" GR.5 HDG BOLT | | | 0.12 |
| 25 | 27-5200-005 | 84 | 1/2 A36 HDG FLAT WASHER | | | 0.04 |
| 26 | 27-5210-005 | 60 | 1/2 HDG LOCK WASHER | | | 0.01 |
| 27 | 27-5222-005 | 60 | 1/2 HDG HEX NUT | | | 0.04 |
| 28 | 27-6060-005 | 12 | HDG - 1/2" x 2-1/2" x 4" U-BOLT ASSEMBLY | | HDG | 0.76 |
| 29 | 27-6040-005 | 12 | GALV. 3/8" x 2" x 4" U-BOLT ASSEMBLY | | | 0.38 |

THIS DESIGN AND INFORMATION CONTAINED ON THIS PRINT IS THE PROPERTY OF VALLEY FAB CORPORATION. ANY REPRODUCTION, DUPLICATION OR TRANSFER OF THE PROPRIETARY CONTENT IS PROHIBITED WITHOUT WRITTEN PERMISSION.

STANDARD TOLERANCES:
(UNLESS OTHERWISE NOTED)
FRACTIONS ±1/16"
DECIMALS ±0.01"
ANGLES ±0.5°

NEWAVE
TOWER COMPONENTS, 503-792-3739
10910 PORTLAND RD. BROOKS, OR 97305

TOTAL WT: 1087.7 LB
QTY:
FINISH:
JOB #:

TITLE:
**10'-6" PIPE FACE, V-FRAME, ADJ. TAPER,
FITS 12" TO 36" O.D MONOPOLE**
SERIES: MONOPOLE MOUNTING

DRAWN BY: DATE: CHK'D BY:
KY 1/17/2023 -
DRAWING NO.
M36-AM1004-10S

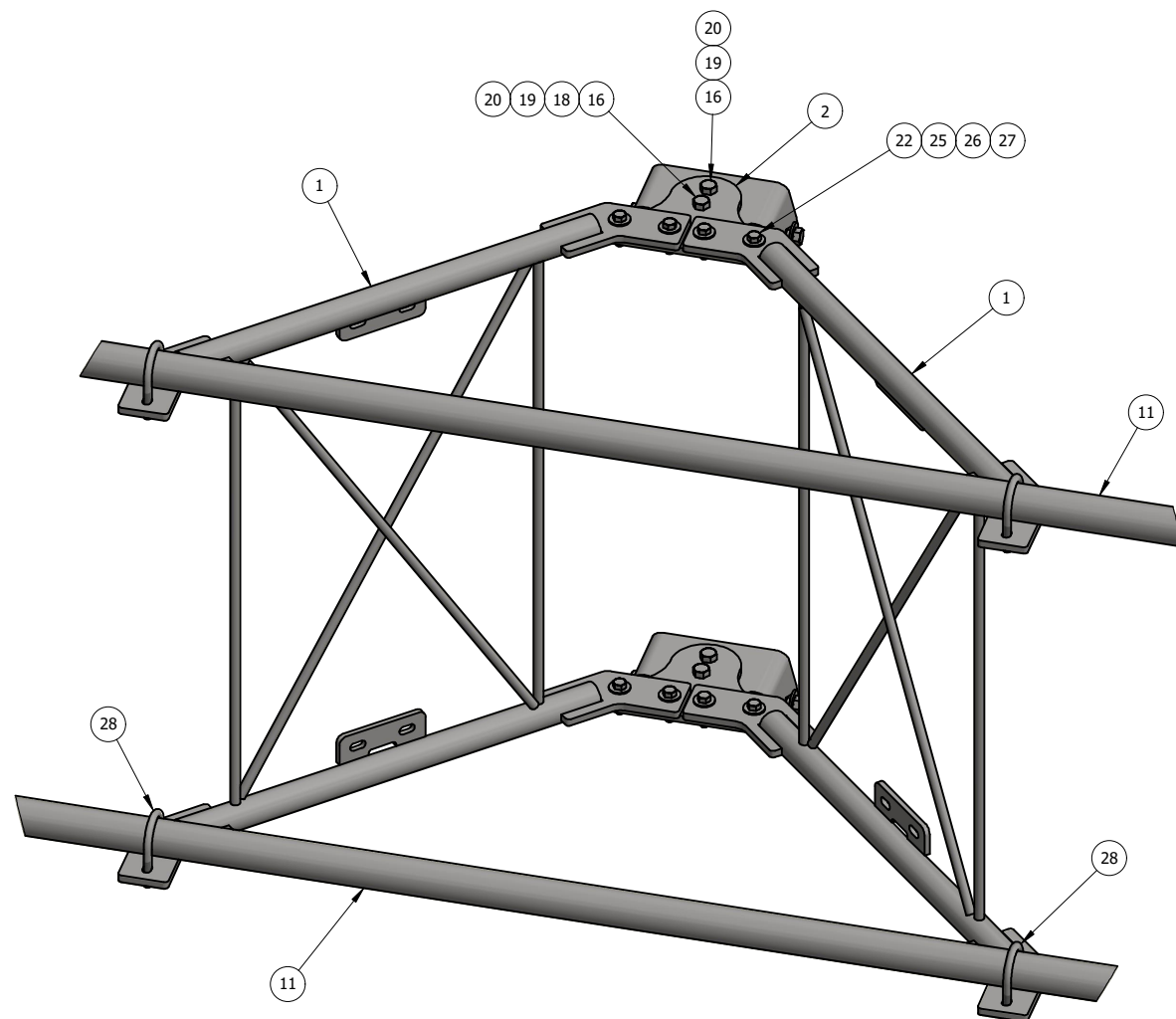

V-FRAME - DETAIL

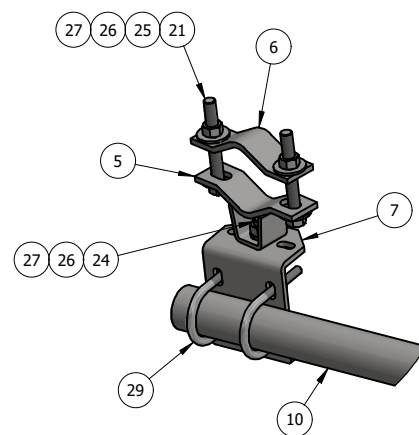

DETAIL - C

STIFF ARM
PIPE FACE
CONNECTION

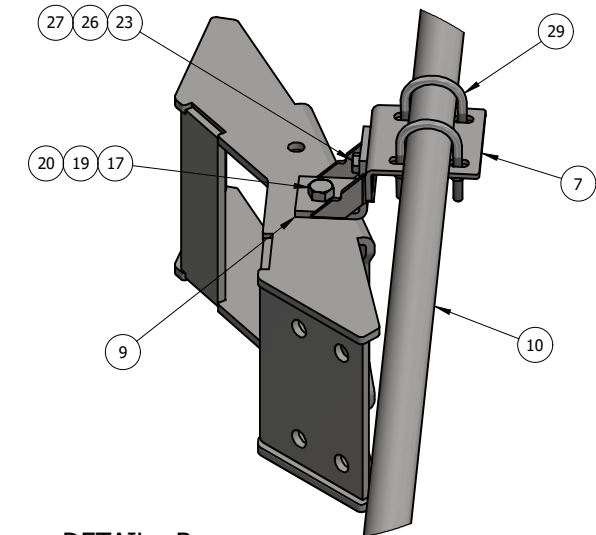

DETAIL - B

STIFF ARM
RING MOUNT
CONNECTION

| ITEM | PART # | QTY | DESCRIPTION | LENGTH | FINISH | UNIT WT |
|------|---------------|-----|--|--------|---------|---------|
| 1 | AM1004.01 | 6 | V-FRAME WELDMENT | | HDG | 46.58 |
| 2 | AM1004.07 | 6 | 1/2" PLATE | | BARE | 7.39 |
| 3 | AM1004.08 | 6 | 3/8 PLATE | | BARE | 8.91 |
| 4 | AM1028-U.02 | 6 | 3/8" PLATE | | HDG | 12.65 |
| 5 | AM1030-23M.02 | 3 | STIFF ARM HALF CLAMP WELDMENT | | HDG | 0.92 |
| 6 | AM1030-23M.03 | 3 | 1/4" PLATE | | SEE W/O | 0.58 |
| 7 | AM1031.03 | 6 | 1/4" PLATE | | HDG | 1.79 |
| 8 | M1236-3.01 | 6 | UNIV. 12" TO 36" OD RING MOUNT WELDMENT | | HDG | 38.96 |
| 9 | MCMX.04 | 3 | CHAIN MOUNT CLEVIS BOLT ATTACHMENT | | HDG | 1.39 |
| 10 | P178-84 | 3 | 1 1/2" STD PIPE | 7' | HDG | 19.04 |
| 11 | P23-126 | 6 | 2" STD PIPE | 10'-6" | HDG | 38.40 |
| 12 | 27-5580-005 | 12 | 3/4" x 28" B7 HDG ALL-THREAD | 2'-4" | | 3.51 |
| 13 | 27-5481-005 | 24 | 3/4 A36 HDG FLAT WASHER | | | 0.11 |
| 14 | 27-5490-005 | 24 | 3/4 HDG LOCK WASHER | | | 0.04 |
| 15 | 27-5500-005 | 24 | 3/4 HDG HEAVY HEX NUT | | | 0.21 |
| 16 | 27-4403-005 | 24 | 5/8 x 2 GR.5 HDG BOLT | | | 0.27 |
| 17 | 27-4402-005 | 3 | 5/8" x 1 3/4" GR.5 HDG BOLT | | | 0.25 |
| 18 | 27-5370-005 | 30 | 5/8 A36 HDG FLAT WASHER | | | 0.08 |
| 19 | 27-5380-005 | 27 | 5/8 HDG LOCK WASHER | | | 0.03 |
| 20 | 27-5391-005 | 27 | 5/8" HDG HEX NUT | | | 0.08 |
| 21 | 27-4310-005 | 6 | GALV. 1/2" x 4" GR.5 FULL THREADED BOLT | | | 0.27 |
| 22 | 27-4303-005 | 48 | 1/2" x 2" GR.5 HDG BOLT | | | 0.16 |
| 23 | 27-4301-005 | 3 | 1/2" x 1 1/2" GR.5 HDG BOLT | | | 0.13 |
| 24 | 27-4300-005 | 3 | 1/2" x 1 1/4" GR.5 HDG BOLT | | | 0.12 |
| 25 | 27-5200-005 | 84 | 1/2 A36 HDG FLAT WASHER | | | 0.04 |
| 26 | 27-5210-005 | 60 | 1/2 HDG LOCK WASHER | | | 0.01 |
| 27 | 27-5222-005 | 60 | 1/2 HDG HEX NUT | | | 0.04 |
| 28 | 27-6060-005 | 12 | HDG - 1/2" x 2-1/2" x 4" U-BOLT ASSEMBLY | | HDG | 0.76 |
| 29 | 27-6040-005 | 12 | GALV. 3/8" x 2" x 4" U-BOLT ASSEMBLY | | | 0.38 |

THIS DESIGN AND INFORMATION CONTAINED ON THIS PRINT IS THE PROPERTY OF VALLEY FAB CORPORATION. ANY REPRODUCTION, DUPLICATION OR TRANSFER OF THE PROPRIETARY CONTENT IS PROHIBITED WITHOUT WRITTEN PERMISSION.

STANDARD TOLERANCES:
(UNLESS OTHERWISE NOTED)
FRACTIONS ±1/16"
DECIMALS ±0.01"
ANGLES ±0.5°



TOWER COMPONENTS, 503-792-3739
10910 PORTLAND RD. BROOKS, OR 97305

TOTAL WT: 1087.7 LB

QTY:

FINISH:

JOB #:

TITLE:
10'-6" PIPE FACE, V-FRAME, ADJ. TAPER,
FITS 12" TO 36" O.D MONOPOLE

SERIES: MONOPOLE MOUNTING

SHEET: 2 OF 3

DRAWN BY: KY
DATE: 1/17/2023
CHK'D BY: -

DRAWING NO.
M36-AM1004-10S

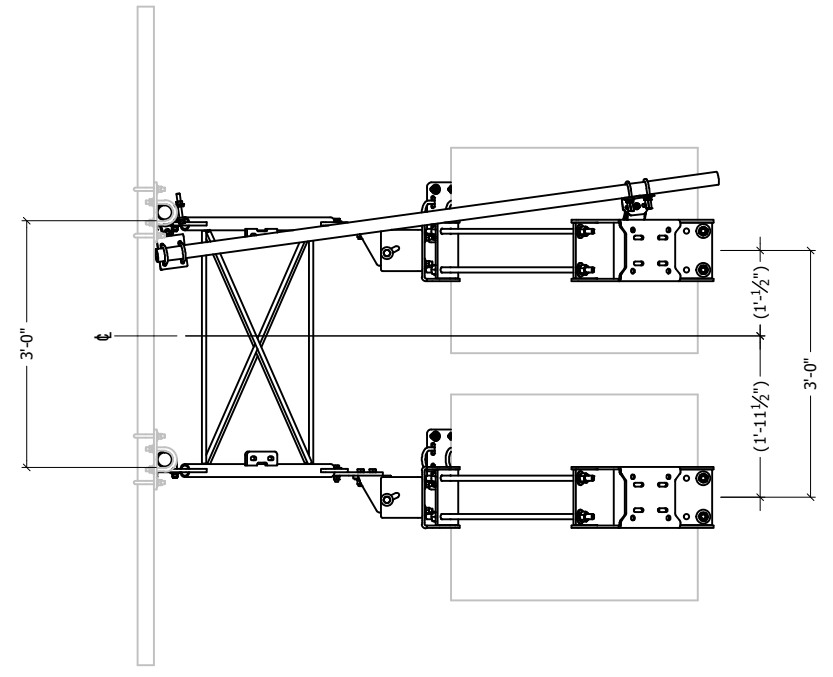
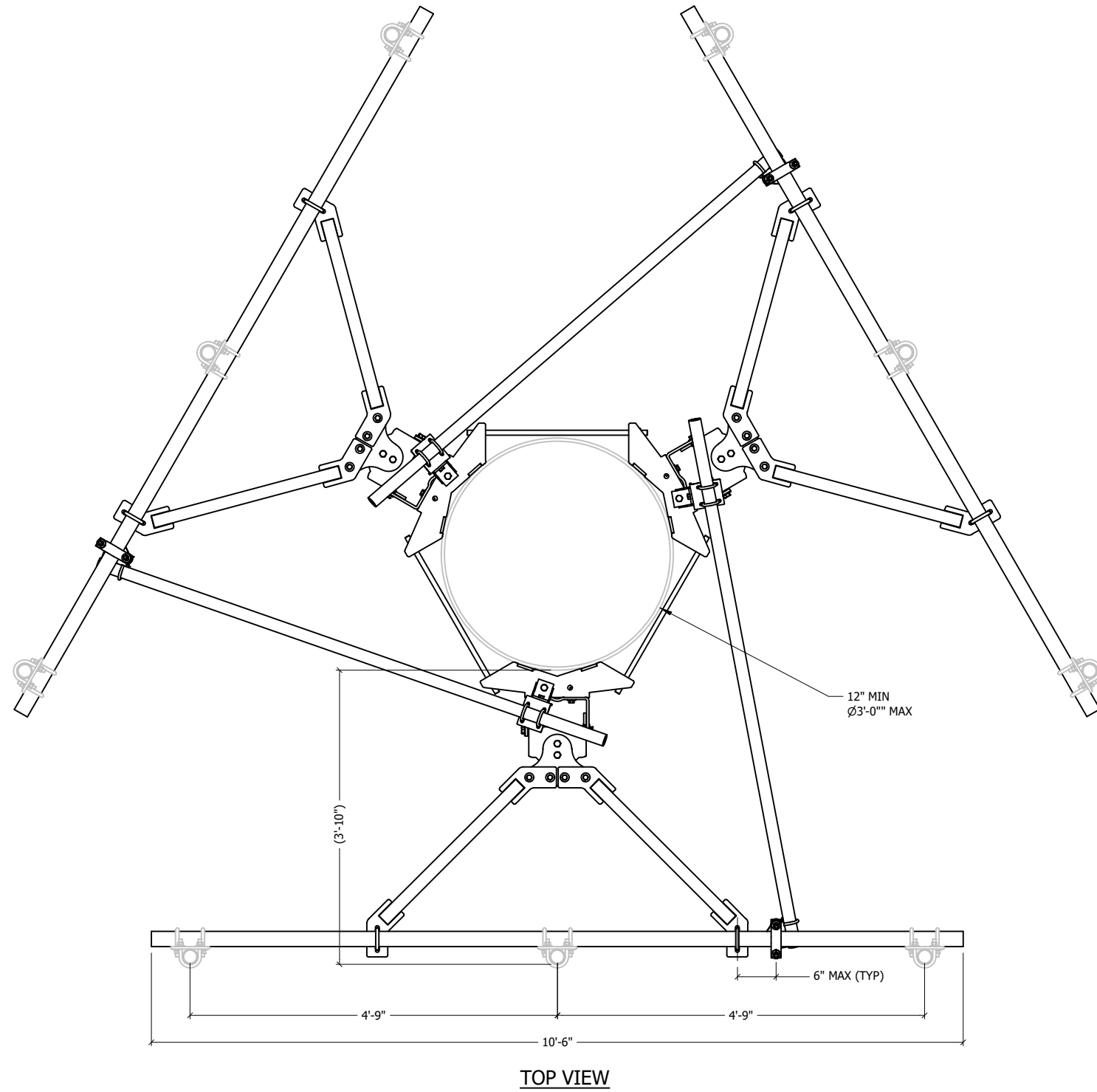

| | |
|---|----------------------------|
| THIS DESIGN AND INFORMATION CONTAINED ON THIS PRINT IS THE PROPERTY OF VALLEY FAB CORPORATION. ANY REPRODUCTION, DUPLICATION OR TRANSFER OF THE PROPRIETARY CONTENT IS PROHIBITED WITHOUT WRITTEN PERMISSION. | |
| STANDARD TOLERANCES: (UNLESS OTHERWISE NOTED) | TOTAL WT: 1087.7 LB |
| FRACTIONS ±1/16" | QTY: |
| DECIMALS ±0.01" | FINISH: |
| ANGLES ±0.5° | JOB #: |



| | | | | |
|--|---------------|-------------------------------|--------------------|----------------|
| TITLE: 10'-6" PIPE FACE, V-FRAME, ADJ. TAPER, FITS 12" TO 36" O.D MONOPOLE | | DRAWN BY: KY | DATE: 1/17/2023 | CHK'D BY: - |
| SERIES: MONOPOLE MOUNTING | SHEET: 3 OF 3 | DRAWING NO. M36-AM1004-10S | | |