

REV	BY	DESCRIPTION	DATE
A	RAJ	SEE MODEL I PROPERTIES/COMMENTS	5/13/2021

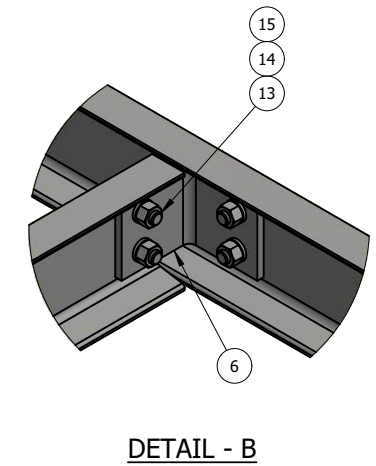

EA. BAR GRATING PANEL GETS (6) G-CLIPS TO FASTEN TO PLATFORM

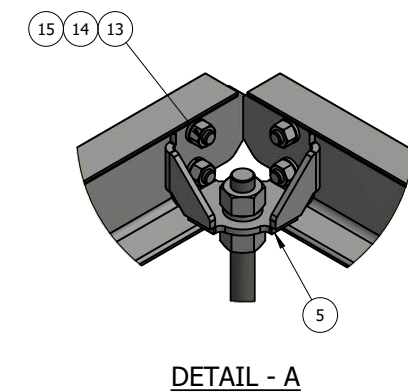
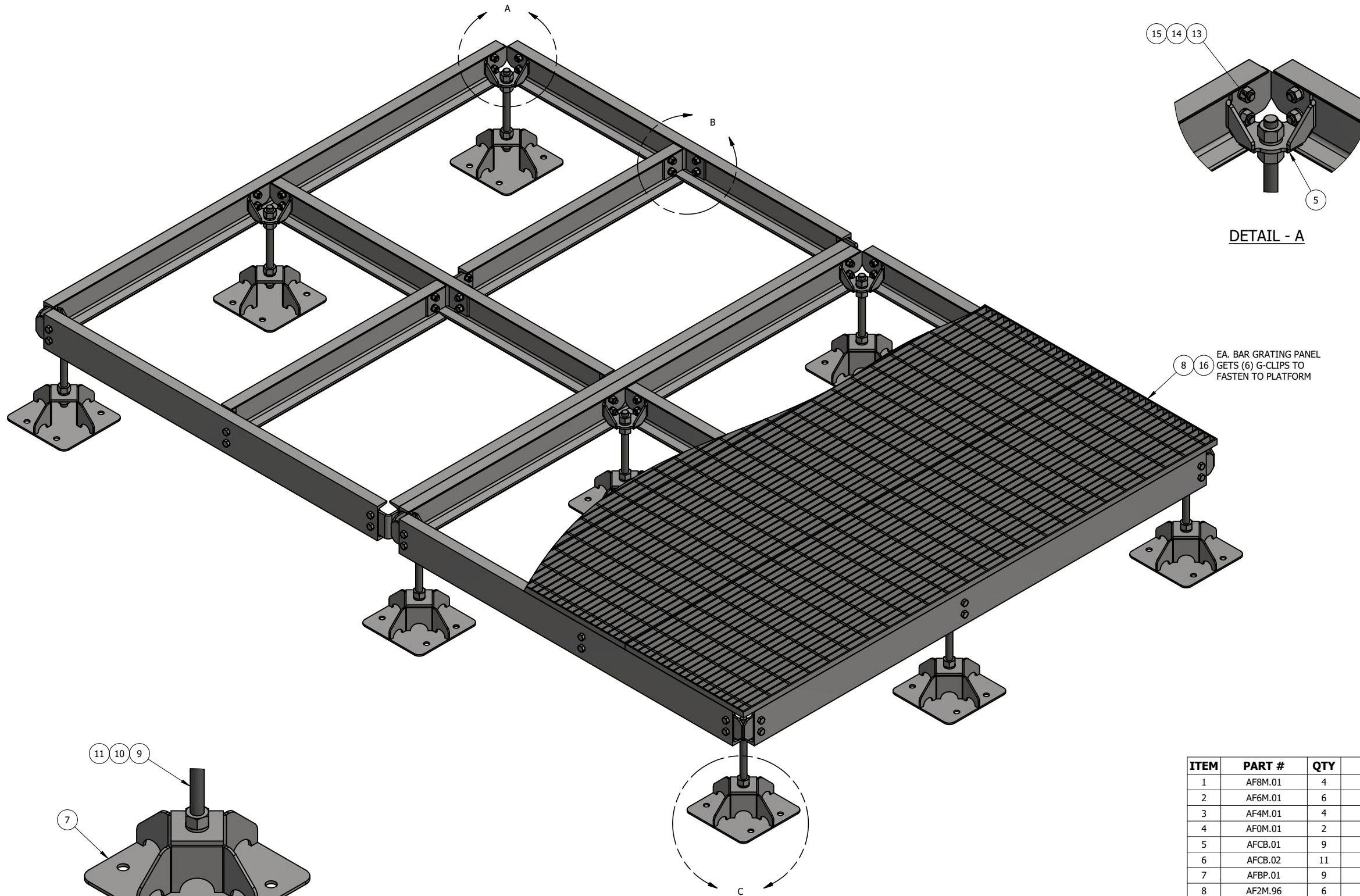
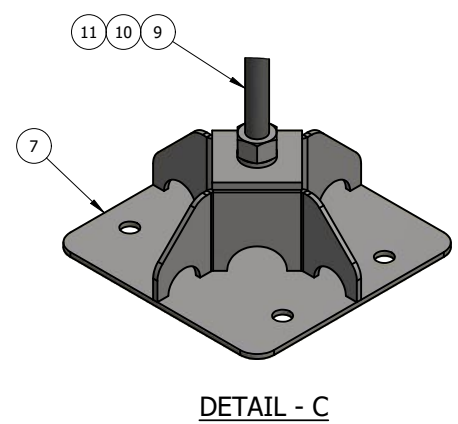

ITEM	PART #	QTY	DESCRIPTION	LENGTH	FINISH	UNIT WT
1	AF8M.01	4	C6x8.2	7'-7 5/8"	HDG	68.36
2	AF6M.01	6	C6x8.2	5'-7 5/8"	HDG	50.41
3	AF4M.01	4	C6x8.2	3'-7 5/8"	HDG	32.51
4	AF0M.01	2	3/16" PLATE		HDG	0.46
5	AFCB.01	9	5/16" PLATE		HDG	4.56
6	AFCB.02	11	3/8" PLATE		SEE W/O	3.30
7	AFBP.01	9	BASE PLATE WELDMENT		HDG	15.63
8	AF2M.96	6	(19W-4) 1" x 3/16" B.G. @ 2' WIDE	8'	HDG	117.71
9	27-5740-005	9	1" x 14" A36 HDG ALL-THREAD	1'-2"		3.12
10	27-5704-005	36	1 HDG LOCK WASHER			0.09
11	27-5700-005	36	1 HDG HEAVY HEX NUT			0.47
12	27-4404-005	10	5/8" x 2 1/4" GR.5 HDG BOLT			0.29
13	27-4401-005	60	5/8" x 1 1/2" GR.5 HDG BOLT			0.23
14	27-5380-005	70	5/8 HDG LOCK WASHER			0.03
15	27-5391-005	70	5/8" HDG HEX NUT			0.08
16	25-GG1A CLIP	36	GRATING G-CLIP			0.00

THIS DESIGN AND INFORMATION CONTAINED ON THIS PRINT IS THE PROPERTY OF VALLEY FAB CORPORATION. ANY REPRODUCTION, DUPLICATION OR TRANSFER OF THE PROPRIETARY CONTENT IS PROHIBITED WITHOUT WRITTEN PERMISSION.

STANDARD TOLERANCES:
(UNLESS OTHERWISE NOTED)
FRACTIONS ±1/16"
DECIMALS ±0.01"
ANGLES ±0.5°

NEWAVE
TOWER COMPONENTS, 503-792-3739
10910 PORTLAND RD. BROOKS, OR 97305

TOTAL WT: 1703.65 LB
QTY:
FINISH: HDG
JOB #:

TITLE:	8' x 12' MODULAR PLATFORM WITH (9) ADJUSTABLE FEET	DRAWN BY:	DATE:	CHK'D BY:
		KY	9/25/2020	
SERIES: PLATFORMS	SHEET: 1 OF 2	DRAWING NO. AF812M-9		

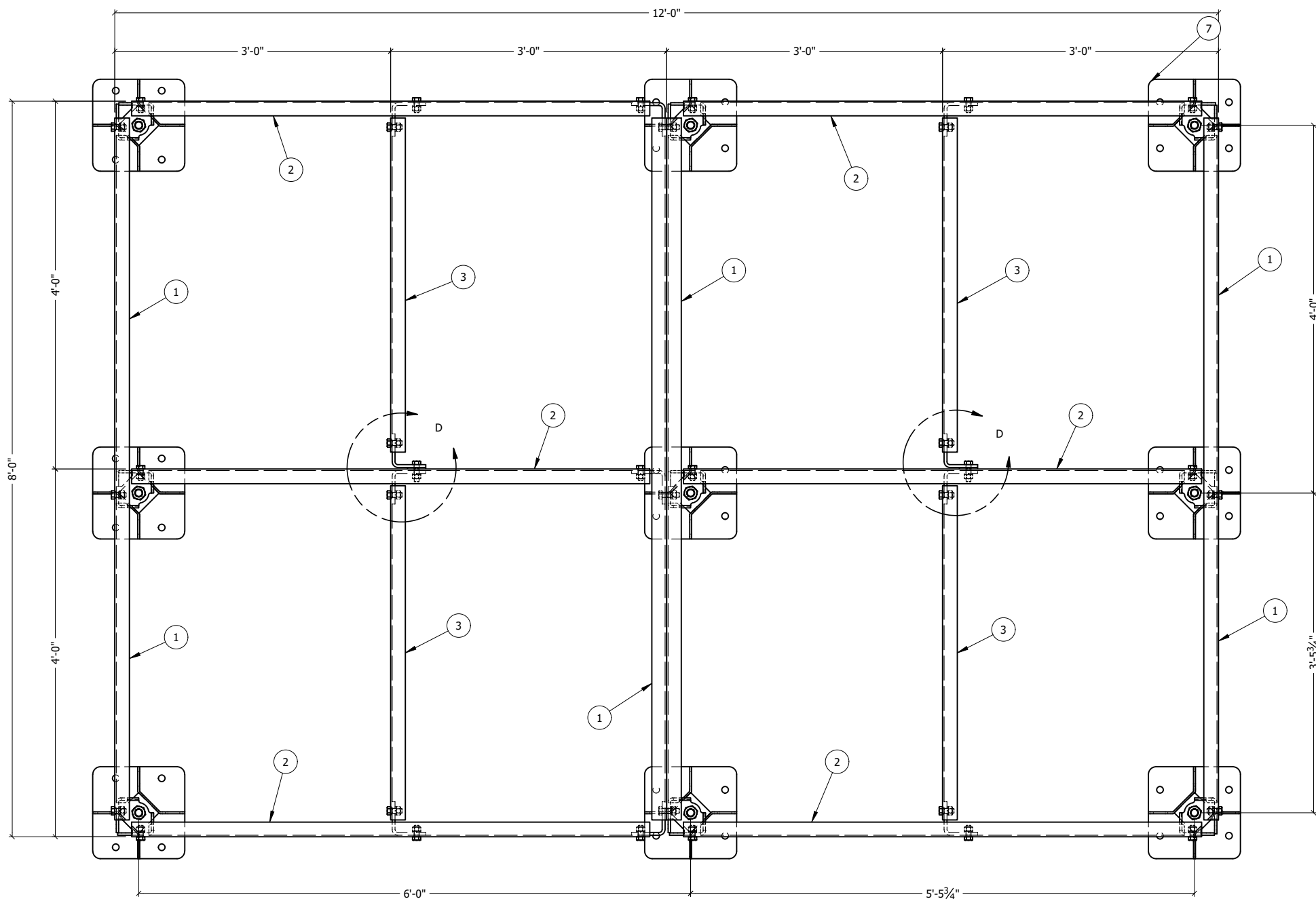

PLAN VIEW

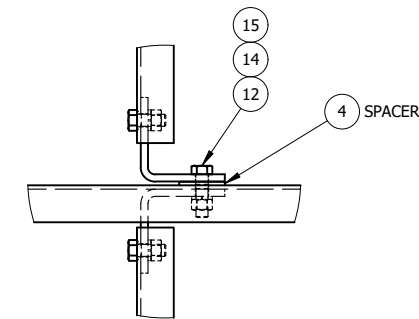

DETAIL - D

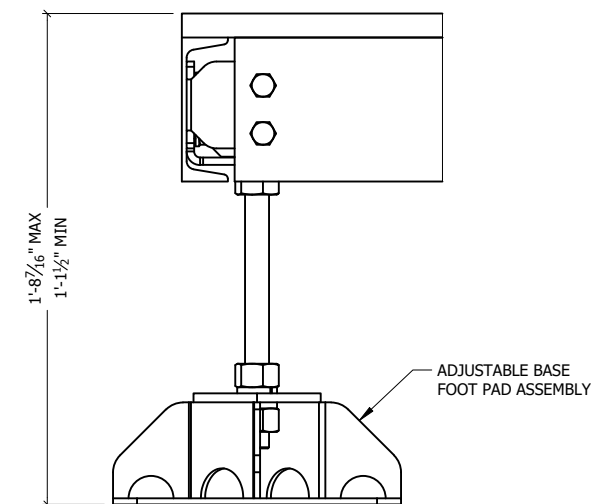

ELEVATION

ITEM	PART #	QTY	DESCRIPTION	LENGTH	FINISH	UNIT WT
1	AF8M.01	4	C6x8.2	7'-7 5/8"	HDG	68.36
2	AF6M.01	6	C6x8.2	5'-7 5/8"	HDG	50.41
3	AF4M.01	4	C6x8.2	3'-7 5/8"	HDG	32.51
4	AF0M.01	2	3/16" PLATE		HDG	0.46
5	AFCB.01	9	5/16" PLATE		HDG	4.56
6	AFCB.02	11	3/8" PLATE		SEE W/O	3.30
7	AFBP.01	9	BASE PLATE WELDMENT		HDG	15.63
8	AF2M.96	6	(19W-4) 1" x 3/16" B.G. @ 2' WIDE	8'	HDG	117.71
9	27-5740-005	9	1" x 14" A36 HDG ALL-THREAD	1'-2"		3.12
10	27-5704-005	36	1 HDG LOCK WASHER			0.09
11	27-5700-005	36	1 HDG HEAVY HEX NUT			0.47
12	27-4404-005	10	5/8" x 2 1/4" GR.5 HDG BOLT			0.29
13	27-4401-005	60	5/8" x 1 1/2" GR.5 HDG BOLT			0.23
14	27-5380-005	70	5/8 HDG LOCK WASHER			0.03
15	27-5391-005	70	5/8" HDG HEX NUT			0.08
16	25-GG1A CLIP	36	GRATING G-CLIP			0.00

THIS DESIGN AND INFORMATION CONTAINED ON THIS PRINT IS THE PROPERTY OF VALLEY FAB CORPORATION. ANY REPRODUCTION, DUPLICATION OR TRANSFER OF THE PROPRIETARY CONTENT IS PROHIBITED WITHOUT WRITTEN PERMISSION.

STANDARD TOLERANCES:
(UNLESS OTHERWISE NOTED)
FRACTIONS ±1/16"
DECIMALS ±0.01"
ANGLES ±0.5°



TOWER COMPONENTS, 503-792-3739
10910 PORTLAND RD. BROOKS, OR 97305

TOTAL WT: 1703.65 LB

QTY:

FINISH: HDG

JOB #:

TITLE: 8' x 12' MODULAR PLATFORM WITH (9) ADJUSTABLE FEET
SERIES: PLATFORMS SHEET: 2 OF 2

DRAWN BY: KY DATE: 9/25/2020
CHK'D BY:
DRAWING NO. AF812M-9