

REV	BY	DESCRIPTION	DATE
A	KY	SEE MODEL IPROPERTIES/COMMENTS	7/29/2020

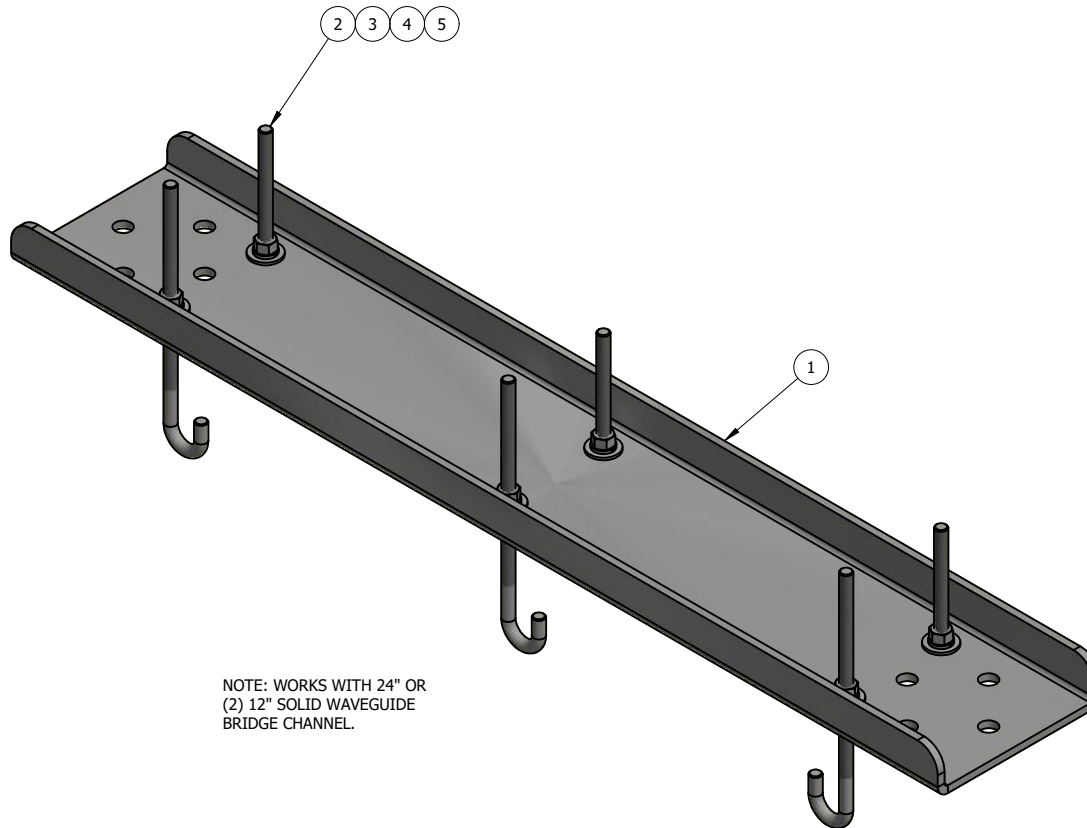

NOTE: WORKS WITH 24" OR
(2) 12" SOLID WAVEGUIDE
BRIDGE CHANNEL.

ITEM	PART #	QTY	DESCRIPTION	LENGTH	FINISH	UNIT WT
1	WB5017-CH.01	1	1/4" PLATE		HDG	19.81
2	27-5010-005	6	3/8 A36 HDG FLAT WASHER			0.01
3	27-5020-005	6	3/8 HDG LOCK WASHER			0.01
4	27-5030-005	6	3/8" HDG HEX NUT			0.02
5	27-5190-005	6	GALV. 3/8" x 8" J-BOLT W/ 3/4" SPACING			0.31

THIS DESIGN AND INFORMATION CONTAINED ON THIS PRINT IS THE PROPERTY OF VALLEY FAB CORPORATION. ANY REPRODUCTION, DUPLICATION OR TRANSFER OF THE PROPRIETARY CONTENT IS PROHIBITED WITHOUT WRITTEN PERMISSION.

STANDARD TOLERANCES:
(UNLESS OTHERWISE NOTED)
FRACTIONS ±1/16"
DECIMALS ±0.01"
ANGLES ±0.5°

NEWAVE
TOWER COMPONENTS. 503-792-3739
10910 PORTLAND RD. BROOKS, OR 97305

TOTAL WT: 21.95 LB

QTY:

FINISH:

JOB #:

TITLE:

CHANNEL SUPPORT BRACKET KIT
FOR DOUBLE PIPE

DRAWN BY:

KY

DATE:

7/17/2018

CHK'D BY:

-

DRAWING NO.

WB5017-CH

SERIES: COAX ICE BRIDGE

SHEET: 1 OF 1