

REV	BY	DESCRIPTION	DATE
A	KY	SEE MODEL I PROPERTIES/COMMENTS	7/29/2020

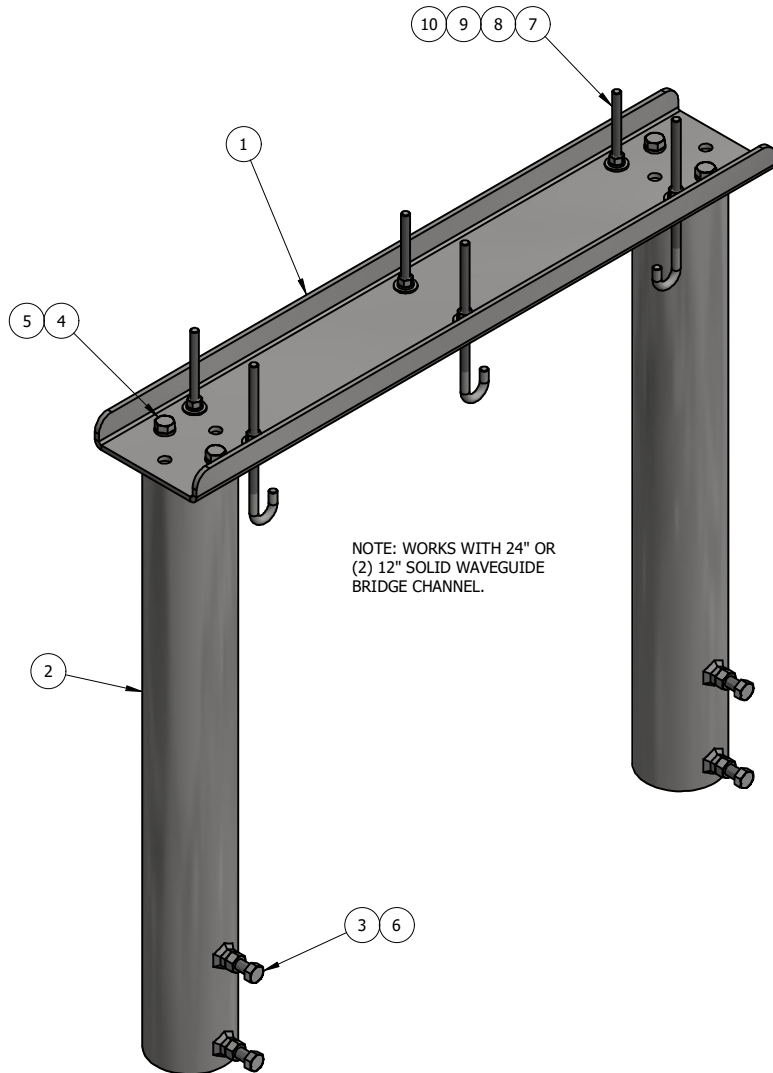

NOTE: WORKS WITH 24" OR (2) 12" SOLID WAVEGUIDE BRIDGE CHANNEL.

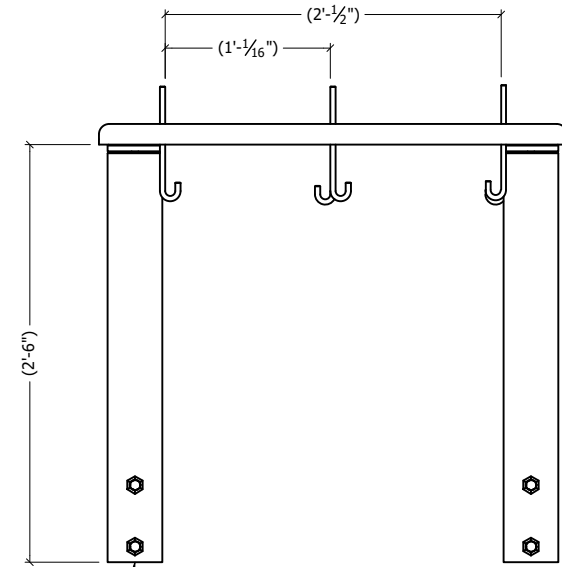

SLIDES OVER 3-1/2" O.D POST

FRONT VIEW

ITEM	PART #	QTY	DESCRIPTION	LENGTH	FINISH	UNIT WT
1	WB5017-CH.01	1	1/4" PLATE		HDG	19.81
2	PH35.01	2	ADJUSTABLE PIPE HEAD BRIDGE SUPPORT		HDG	14.70
3	27-5261-005	4	GALV. 1/2" x 2" GR.5 FULL THREADED BOLT			0.16
4	27-4301-005	4	1/2" x 1 1/2" GR.5 HDG BOLT			0.13
5	27-5210-005	4	1/2" HDG LOCK WASHER			0.01
6	27-5222-005	4	1/2 HDG HEX NUT			0.04
7	27-5190-005	6	GALV. 3/8" x 8" J-BOLT W/ 3/4" SPACING			0.31
8	27-5010-005	6	3/8 A36 HDG FLAT WASHER			0.01
9	27-5020-005	6	3/8 HDG LOCK WASHER			0.01
10	27-5030-005	6	3/8" HDG HEX NUT			0.02

THIS DESIGN AND INFORMATION CONTAINED ON THIS PRINT IS THE PROPERTY OF VALLEY FAB CORPORATION. ANY REPRODUCTION, DUPLICATION OR TRANSFER OF THE PROPRIETARY CONTENT IS PROHIBITED WITHOUT WRITTEN PERMISSION.

STANDARD TOLERANCES:

(UNLESS OTHERWISE NOTED)

FRACTIONS ±1/16"
 DECIMALS ±0.01"
 ANGLES ±0.5°



TOTAL WT: 52.75 LB

QTY:

FINISH:

JOB #:

TITLE:

CHANNEL SUPPORT BRACKET KIT WITH PIPE HEADS

SERIES: COAX ICE BRIDGE

SHEET: 1 OF 1

DRAWN BY:

KY

DATE:

7/17/2018

CHK'D BY:

KY

DRAWING NO.

WB5017