

ITEM	PART #	QTY	DESCRIPTION	LENGTH	FINISH	UNIT WT
1	AM1004.01	2	V-FRAME WELDMENT		HDG	46.58
2	AM1004.07	2	1/2" PLATE		BARE	7.39
3	AM1004.08	2	3/8" PLATE		BARE	8.91
4	AM1028-U.02	2	3/8" PLATE		HDG	12.61
5	AM1028-4R.01	2	UNIVERSAL CLAMP PLATE WELDMENT		HDG	7.38
6	AM1028-4U.01	4	1/4" PLATE		HDG	2.07
7	AM1030-23M.02	2	STIFF ARM HALF CLAMP WELDMENT		HDG	0.92
8	AM1030-23M.03	2	1/4" PLATE		SEE W/O	0.58
9	AM1031.03	4	1/4" PLATE		HDG	1.79
10	AM1031HD.03	4	3/16" PLATE		HDG	1.58
11	P23-72	2	2" STD PIPE	6'	HDG	21.94
12	P178-126	2	1 1/2" STD PIPE	10'-6"	HDG	28.57
13	27-4403-005	8	5/8 x 2 GR.5 HDG BOLT			0.27
14	27-5370-005	10	HDG - 5/8" FLAT WASHER, USS			0.08
15	27-5380-005	8	5/8 HDG LOCK WASHER			0.03
16	27-5391-005	8	5/8" HDG HEX NUT			0.08
17	TR12-10	4	1/2" x 10" A36 HDG ALL-THREAD	10"		0.56
18	27-4320-005	8	GALV. 1/2" x 7" GR.5 FULL THREADED BOLT			0.44
19	27-4310-005	4	GALV. 1/2" x 4" GR.5 FULL THREADED BOLT			0.27
20	27-4303-005	8	1/2" x 2" GR.5 HDG BOLT			0.16
21	27-4300-005	4	1/2" x 1 1/4" GR.5 HDG BOLT			0.12
22	27-5200-005	40	HDG - 1/2" FLAT WASHER, USS			0.04
23	27-5210-005	40	1/2 HDG LOCK WASHER			0.01
24	27-5222-005	40	1/2 HDG HEX NUT			0.04
25	27-6060-005	4	HDG - 1/2" x 2-1/2" x 4" U-BOLT ASSEMBLY		HDG	0.76
26	27-6040-005	8	GALV. 3/8" x 2" x 4" U-BOLT ASSEMBLY			0.38

THIS DESIGN AND INFORMATION CONTAINED ON THIS PRINT IS THE PROPERTY OF VALLEY FAB CORPORATION. ANY REPRODUCTION, DUPLICATION OR TRANSFER OF THE PROPRIETARY CONTENT IS PROHIBITED WITHOUT WRITTEN PERMISSION.

**STANDARD TOLERANCES:**  
 (UNLESS OTHERWISE NOTED)  
 FRACTIONS ±1/16"  
 DECIMALS ±0.01"  
 ANGLES ±0.5°

**NEWAVE**  
 TOWER COMPONENTS, 503-792-3739  
 10910 PORTLAND RD. BROOKS, OR 97305

TOTAL WT: 314.65 LB  
 QTY:  
 FINISH:  
 JOB #:

TITLE: 6' PIPE FACE, V-FRAME, ADJ. TAPER, FITS 1-1/2" TO 5" O.D ROUND LEG, DBL STIFF-ARM

SERIES: TOWER ANTENNA MOUNT SHEET: 1 OF 3

DRAWN BY: KY DATE: 8/11/2022 CHK'D BY: KY  
 DRAWING NO. AM1004-6D

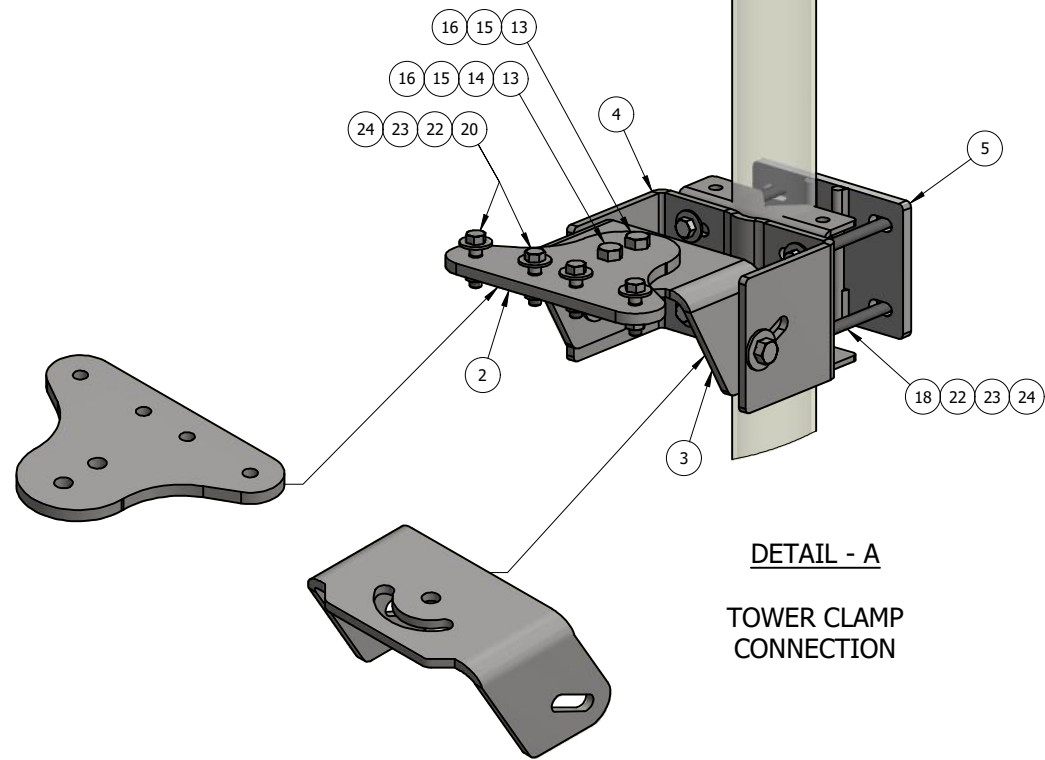

**DETAIL - A**  
TOWER CLAMP CONNECTION

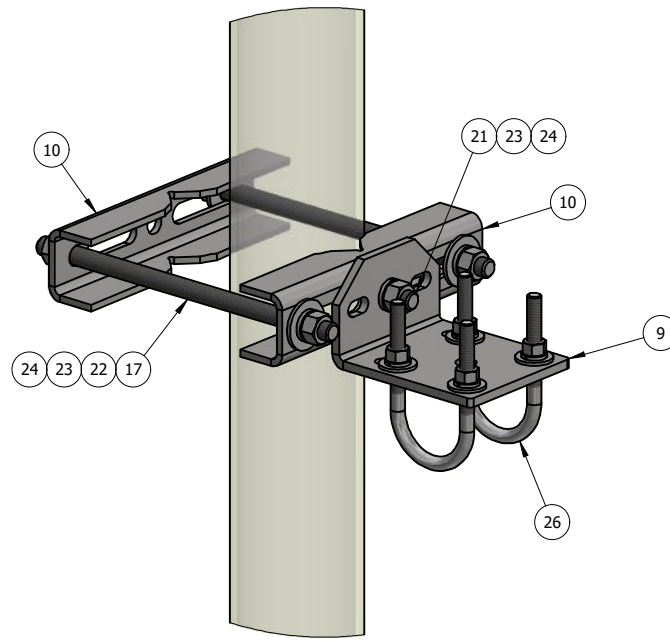

**DETAIL - B**  
STIFF ARM  
TOWER LEG  
CONNECTION

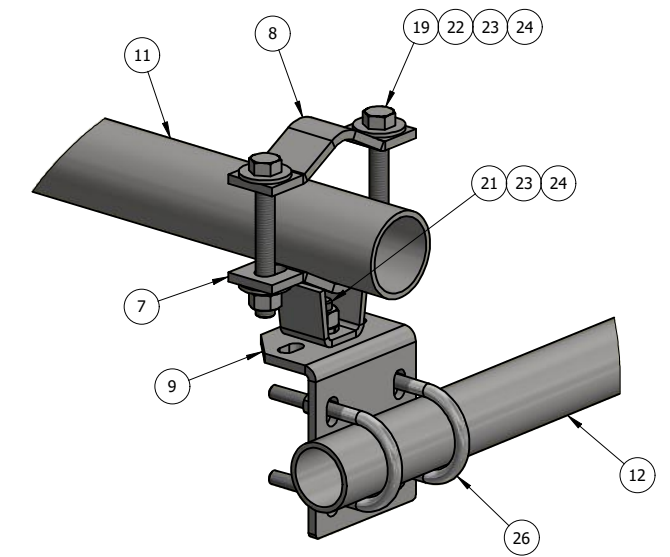

**DETAIL - C**  
STIFF ARM  
PIPE FACE  
CONNECTION

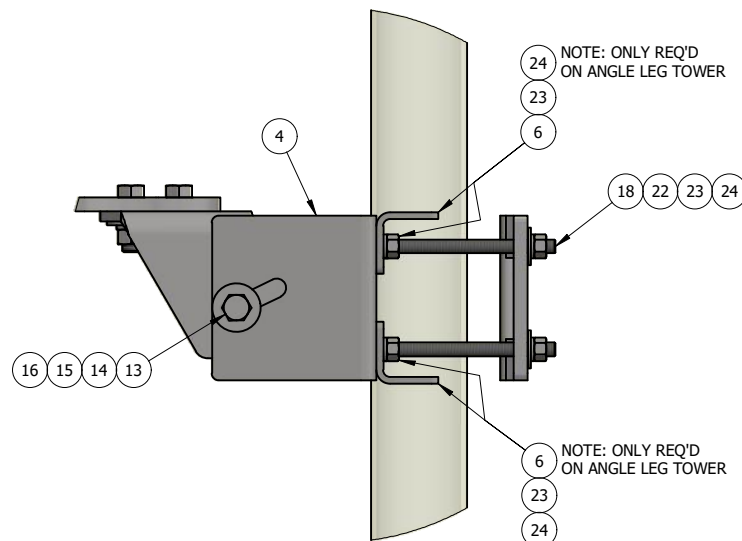

**DETAIL - A**  
SIDE VIEW

ITEM	PART #	QTY	DESCRIPTION	LENGTH	FINISH	UNIT WT
1	AM1004.01	2	V-FRAME WELDMENT		HDG	46.58
2	AM1004.07	2	1/2" PLATE		BARE	7.39
3	AM1004.08	2	3/8 PLATE		BARE	8.91
4	AM1028-U.02	2	3/8" PLATE		HDG	12.61
5	AM1028-4R.01	2	UNIVERSAL CLAMP PLATE WELDMENT		HDG	7.38
6	AM1028-4U.01	4	1/4" PLATE		HDG	2.07
7	AM1030-23M.02	2	STIFF ARM HALF CLAMP WELDMENT		HDG	0.92
8	AM1030-23M.03	2	1/4" PLATE		SEE W/O	0.58
9	AM1031.03	4	1/4" PLATE		HDG	1.79
10	AM1031HD.03	4	3/16" PLATE		HDG	1.58
11	P23-72	2	2" STD PIPE	6'	HDG	21.94
12	P178-126	2	1 1/2" STD PIPE	10'-6"	HDG	28.57
13	27-4403-005	8	5/8 x 2 GR.5 HDG BOLT			0.27
14	27-5370-005	10	HDG - 5/8" FLAT WASHER, USS			0.08
15	27-5380-005	8	5/8 HDG LOCK WASHER			0.03
16	27-5391-005	8	5/8" HDG HEX NUT			0.08
17	TR12-10	4	1/2" x 10" A36 HDG ALL-THREAD	10"		0.56
18	27-4320-005	8	GALV. 1/2" x 7" GR.5 FULL THREADED BOLT			0.44
19	27-4310-005	4	GALV. 1/2" x 4" GR.5 FULL THREADED BOLT			0.27
20	27-4303-005	8	1/2" x 2" GR.5 HDG BOLT			0.16
21	27-4300-005	4	1/2" x 1 1/4" GR.5 HDG BOLT			0.12
22	27-5200-005	40	HDG - 1/2" FLAT WASHER, USS			0.04
23	27-5210-005	40	1/2 HDG LOCK WASHER			0.01
24	27-5222-005	40	1/2 HDG HEX NUT			0.04
25	27-6060-005	4	HDG - 1/2" x 2-1/2" x 4" U-BOLT ASSEMBLY		HDG	0.76
26	27-6040-005	8	GALV. 3/8" x 2" x 4" U-BOLT ASSEMBLY			0.38

THIS DESIGN AND INFORMATION CONTAINED ON THIS PRINT IS THE PROPERTY OF VALLEY FAB CORPORATION. ANY REPRODUCTION, DUPLICATION OR TRANSFER OF THE PROPRIETARY CONTENT IS PROHIBITED WITHOUT WRITTEN PERMISSION.

**STANDARD TOLERANCES:**  
(UNLESS OTHERWISE NOTED)  
FRACTIONS ±1/16"  
DECIMALS ±0.01"  
ANGLES ±0.5°

**NEWAVE**  
TOWER COMPONENTS, 503-792-3739  
10910 PORTLAND RD. BROOKS, OR 97305

TOTAL WT: 314.65 LB  
QTY:  
FINISH:  
JOB #:

TITLE: 6' PIPE FACE, V-FRAME, ADJ. TAPER, FITS 1-1/2" TO 5" O.D ROUND LEG, DBL STIFF-ARM

SERIES: TOWER ANTENNA MOUNT SHEET: 2 OF 3

DRAWN BY: KY DATE: 8/11/2022 CHK'D BY: KY  
DRAWING NO. AM1004-6D

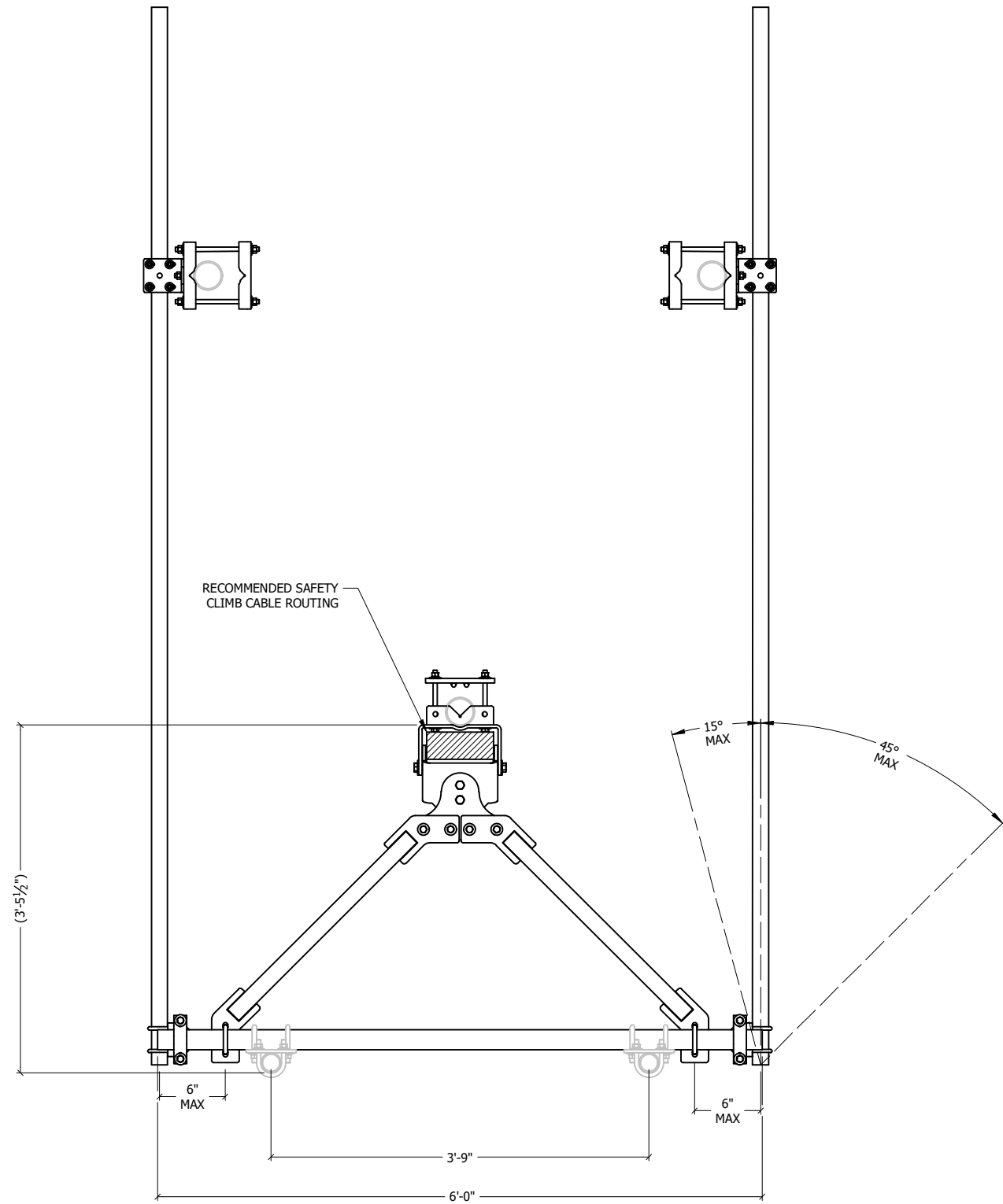

TOP VIEW

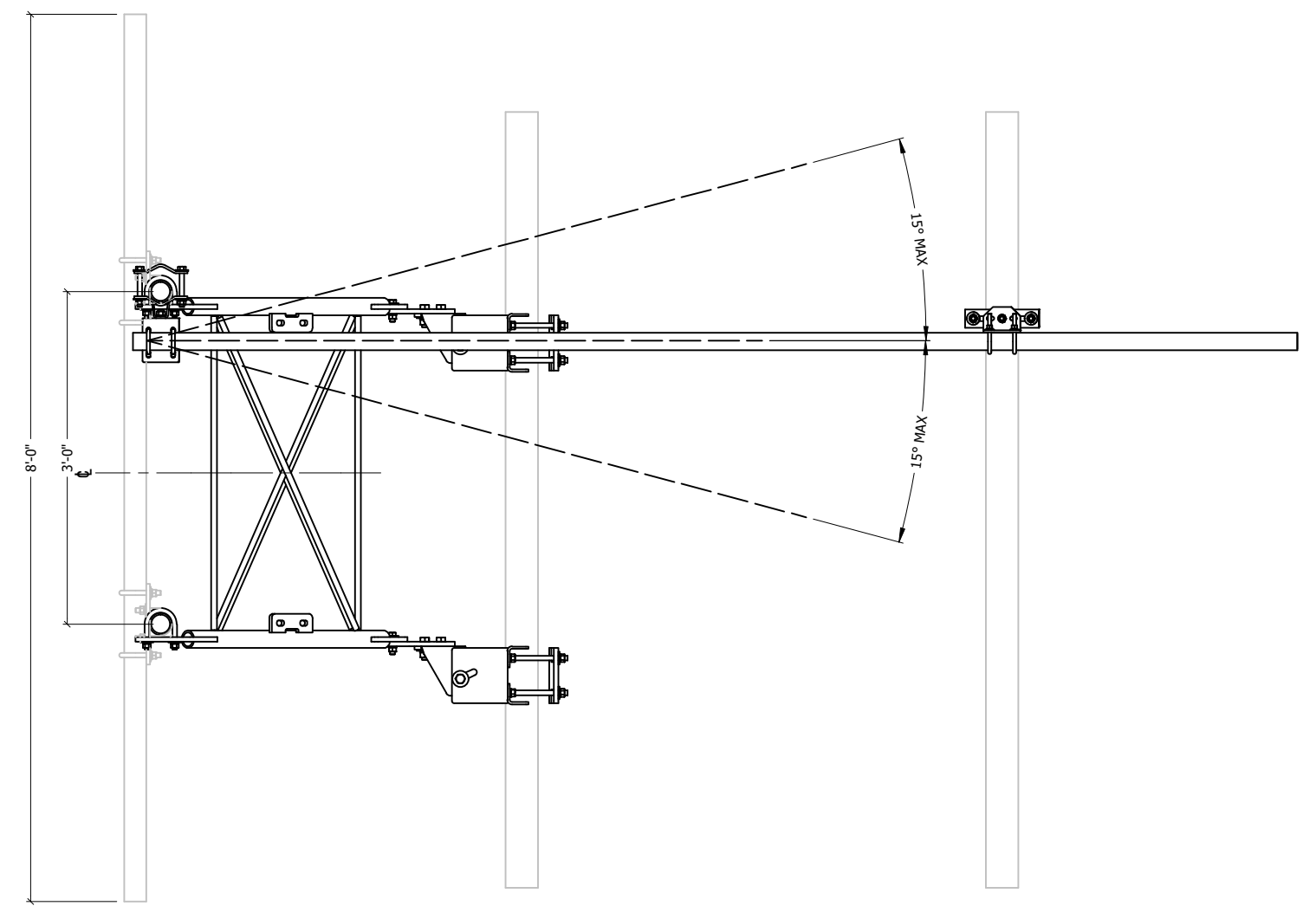

SIDE VIEW

THIS DESIGN AND INFORMATION CONTAINED ON THIS PRINT IS THE PROPERTY OF VALLEY FAB CORPORATION. ANY REPRODUCTION, DUPLICATION OR TRANSFER OF THE PROPRIETARY CONTENT IS PROHIBITED WITHOUT WRITTEN PERMISSION.	
STANDARD TOLERANCES: (UNLESS OTHERWISE NOTED)	 <b>NEWAVE</b> TOWER COMPONENTS, 503-792-3739 10910 PORTLAND RD. BROOKS, OR 97305
FRACTIONS ±1/16" DECIMALS ±0.01" ANGLES ±0.5°	
TOTAL WT: 314.65 LB	
QTY:	
FINISH:	
JOB #:	

TITLE: 6' PIPE FACE, V-FRAME, ADJ. TAPER, FITS 1-1/2" TO 5" O.D ROUND LEG, DBL STIFF-ARM		DRAWN BY: KY	DATE: 8/11/2022	CHK'D BY: KY
SERIES: TOWER ANTENNA MOUNT		SHEET: 3 OF 3		DRAWING NO. AM1004-6D