

ITEM	PART #	QTY	DESCRIPTION	LENGTH	FINISH	UNIT WT
1	AM1004.01	2	V-FRAME WELDMENT		HDG	46.58
2	AM1004.07	2	1/2" PLATE		BARE	7.39
3	AM1004.08	2	3/8 PLATE		BARE	8.91
4	AM1028-U.02	2	3/8" PLATE		HDG	12.65
5	AM1028-4R.01	2	UNIVERSAL CLAMP PLATE WELDMENT		HDG	7.38
6	AM1028-4U.01	4	1/4" PLATE		HDG	2.07
7	AM1030-23M.02	1	STIFF ARM HALF CLAMP WELDMENT		HDG	0.92
8	AM1030-23M.03	1	1/4" PLATE		SEE W/O	0.58
9	AM1031.03	2	1/4" PLATE		HDG	1.79
10	AM1031HD.03	2	3/16" PLATE		HDG	1.58
11	P23-96	2	2" STD PIPE	8'	HDG	29.25
12	P178-126	1	1 1/2" STD PIPE	10'-6"	HDG	28.57
13	27-4403-005	8	5/8 x 2 GR.5 HDG BOLT			0.27
14	27-5370-005	10	HDG - 5/8" FLAT WASHER, USS			0.08
15	27-5380-005	8	5/8 HDG LOCK WASHER			0.03
16	27-5391-005	8	5/8" HDG HEX NUT			0.08
17	TR12-10	2	1/2" x 10" A36 HDG ALL-THREAD	10"		0.56
18	27-4320-005	8	GALV. 1/2" x 7" GR.5 FULL THREADED BOLT			0.44
19	27-4310-005	2	GALV. 1/2" x 4" GR.5 FULL THREADED BOLT			0.27
20	27-4303-005	8	1/2" x 2" GR.5 HDG BOLT			0.16
21	27-4300-005	2	1/2" x 1 1/4" GR.5 HDG BOLT			0.12
22	27-5200-005	32	HDG - 1/2" FLAT WASHER, USS			0.04
23	27-5210-005	32	1/2 HDG LOCK WASHER			0.01
24	27-5222-005	32	1/2 HDG HEX NUT			0.04
25	27-6060-005	4	HDG - 1/2" x 2-1/2" x 4" U-BOLT ASSEMBLY		HDG	0.76
26	27-6040-005	4	GALV. 3/8" x 2" x 4" U-BOLT ASSEMBLY			0.38

THIS DESIGN AND INFORMATION CONTAINED ON THIS PRINT IS THE PROPERTY OF VALLEY FAB CORPORATION. ANY REPRODUCTION, DUPLICATION OR TRANSFER OF THE PROPRIETARY CONTENT IS PROHIBITED WITHOUT WRITTEN PERMISSION.

STANDARD TOLERANCES:
(UNLESS OTHERWISE NOTED)
FRACTIONS ±1/16"
DECIMALS ±0.01"
ANGLES ±0.5°

NEWAVE
TOWER COMPONENTS, 503-792-3739
10910 PORTLAND RD. BROOKS, OR 97305

TOTAL WT: 287.5 LB
QTY:
FINISH:
JOB #:

TITLE: 8' PIPE FACE, V-FRAME, ADJ. TAPER, FITS 1-1/2" TO 5" O.D ROUND LEG, SINGLE STIFF-ARM	DRAWN BY: KY	DATE: 8/11/2022	CHK'D BY: -
SERIES: TOWER ANTENNA MOUNT	SHEET: 1 OF 3		AM1004-8S

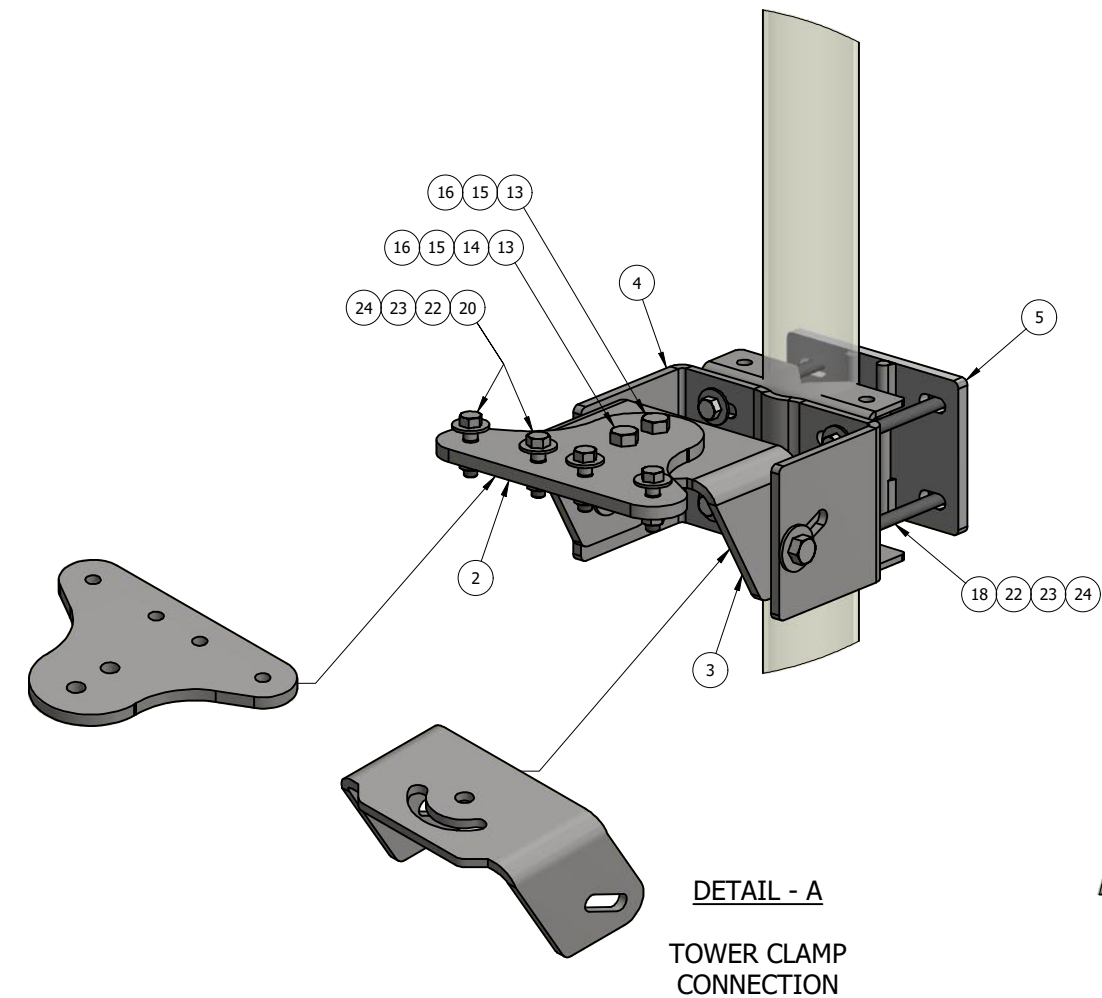

DETAIL - A
TOWER CLAMP CONNECTION

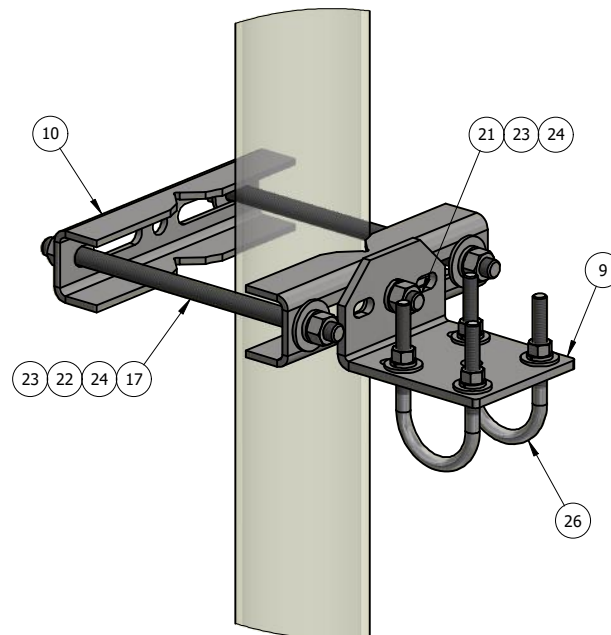

DETAIL - B
STIFF ARM
TOWER LEG
CONNECTION

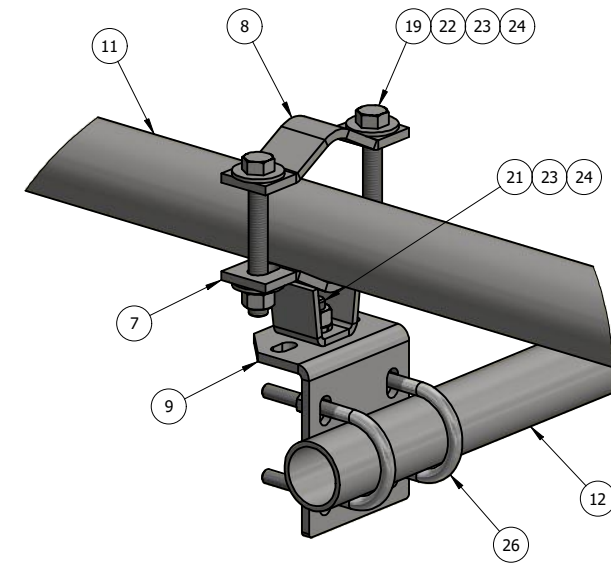

DETAIL - C
STIFF ARM
PIPE FACE
CONNECTION

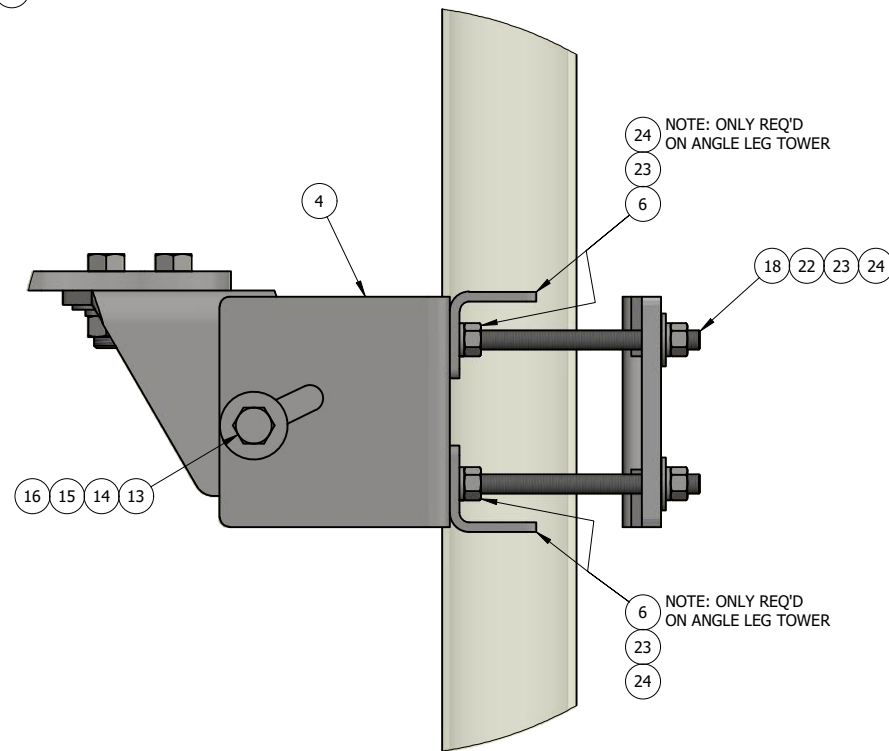

DETAIL - A
SIDE VIEW

ITEM	PART #	QTY	DESCRIPTION	LENGTH	FINISH	UNIT WT
1	AM1004.01	2	V-FRAME WELDMENT		HDG	46.58
2	AM1004.07	2	1/2" PLATE		BARE	7.39
3	AM1004.08	2	3/8" PLATE		BARE	8.91
4	AM1028-U.02	2	3/8" PLATE		HDG	12.65
5	AM1028-4R.01	2	UNIVERSAL CLAMP PLATE WELDMENT		HDG	7.38
6	AM1028-4U.01	4	1/4" PLATE		HDG	2.07
7	AM1030-23M.02	1	STIFF ARM HALF CLAMP WELDMENT		HDG	0.92
8	AM1030-23M.03	1	1/4" PLATE		SEE W/O	0.58
9	AM1031.03	2	1/4" PLATE		HDG	1.79
10	AM1031HD.03	2	3/16" PLATE		HDG	1.58
11	P23-96	2	2" STD PIPE	8'	HDG	29.25
12	P178-126	1	1 1/2" STD PIPE	10'-6"	HDG	28.57
13	27-4403-005	8	5/8 x 2 GR.5 HDG BOLT			0.27
14	27-5370-005	10	HDG - 5/8" FLAT WASHER, USS			0.08
15	27-5380-005	8	5/8 HDG LOCK WASHER			0.03
16	27-5391-005	8	5/8" HDG HEX NUT			0.08
17	TR12-10	2	1/2" x 10" A36 HDG ALL-THREAD	10"		0.56
18	27-4320-005	8	GALV. 1/2" x 7" GR.5 FULL THREADED BOLT			0.44
19	27-4310-005	2	GALV. 1/2" x 4" GR.5 FULL THREADED BOLT			0.27
20	27-4303-005	8	1/2" x 2" GR.5 HDG BOLT			0.16
21	27-4300-005	2	1/2" x 1 1/4" GR.5 HDG BOLT			0.12
22	27-5200-005	32	HDG - 1/2" FLAT WASHER, USS			0.04
23	27-5210-005	32	1/2 HDG LOCK WASHER			0.01
24	27-5222-005	32	1/2 HDG HEX NUT			0.04
25	27-6060-005	4	HDG - 1/2" x 2-1/2" x 4" U-BOLT ASSEMBLY		HDG	0.76
26	27-6040-005	4	GALV. 3/8" x 2" x 4" U-BOLT ASSEMBLY			0.38

THIS DESIGN AND INFORMATION CONTAINED ON THIS PRINT IS THE PROPERTY OF VALLEY FAB CORPORATION. ANY REPRODUCTION, DUPLICATION OR TRANSFER OF THE PROPRIETARY CONTENT IS PROHIBITED WITHOUT WRITTEN PERMISSION.

STANDARD TOLERANCES:
(UNLESS OTHERWISE NOTED)
FRACTIONS ±1/16"
DECIMALS ±0.01"
ANGLES ±0.5°

NEWAVE
TOWER COMPONENTS, 503-792-3739
10910 PORTLAND RD. BROOKS, OR 97305

TOTAL WT: 287.5 LB
QTY:
FINISH:
JOB #:

TITLE: 8' PIPE FACE, V-FRAME, ADJ. TAPER, FITS 1-1/2" TO 5" O.D ROUND LEG, SINGLE STIFF-ARM

SERIES: TOWER ANTENNA MOUNT SHEET: 2 OF 3

DRAWN BY: KY DATE: 8/11/2022 CHK'D BY: -

DRAWING NO. AM1004-8S

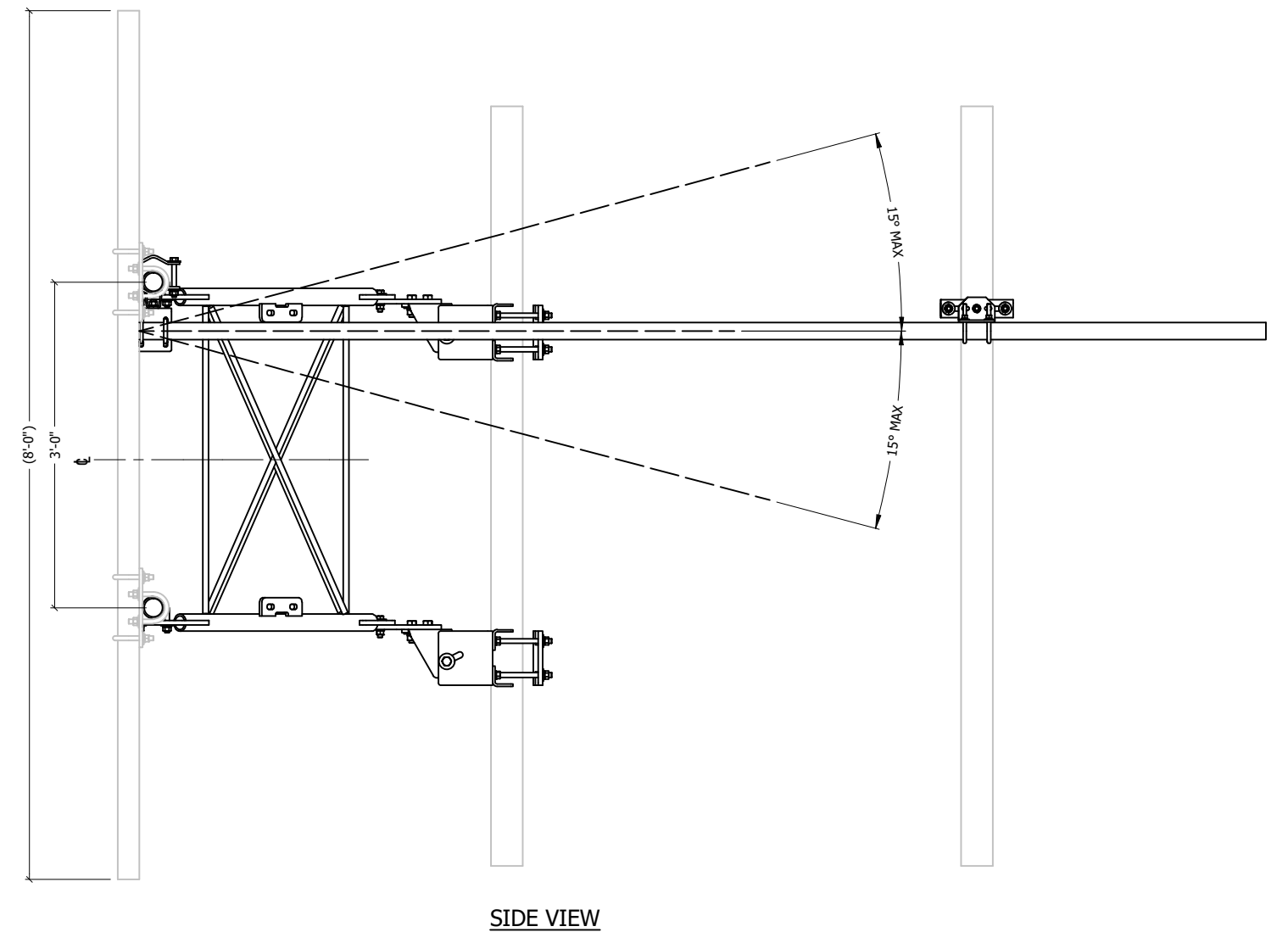
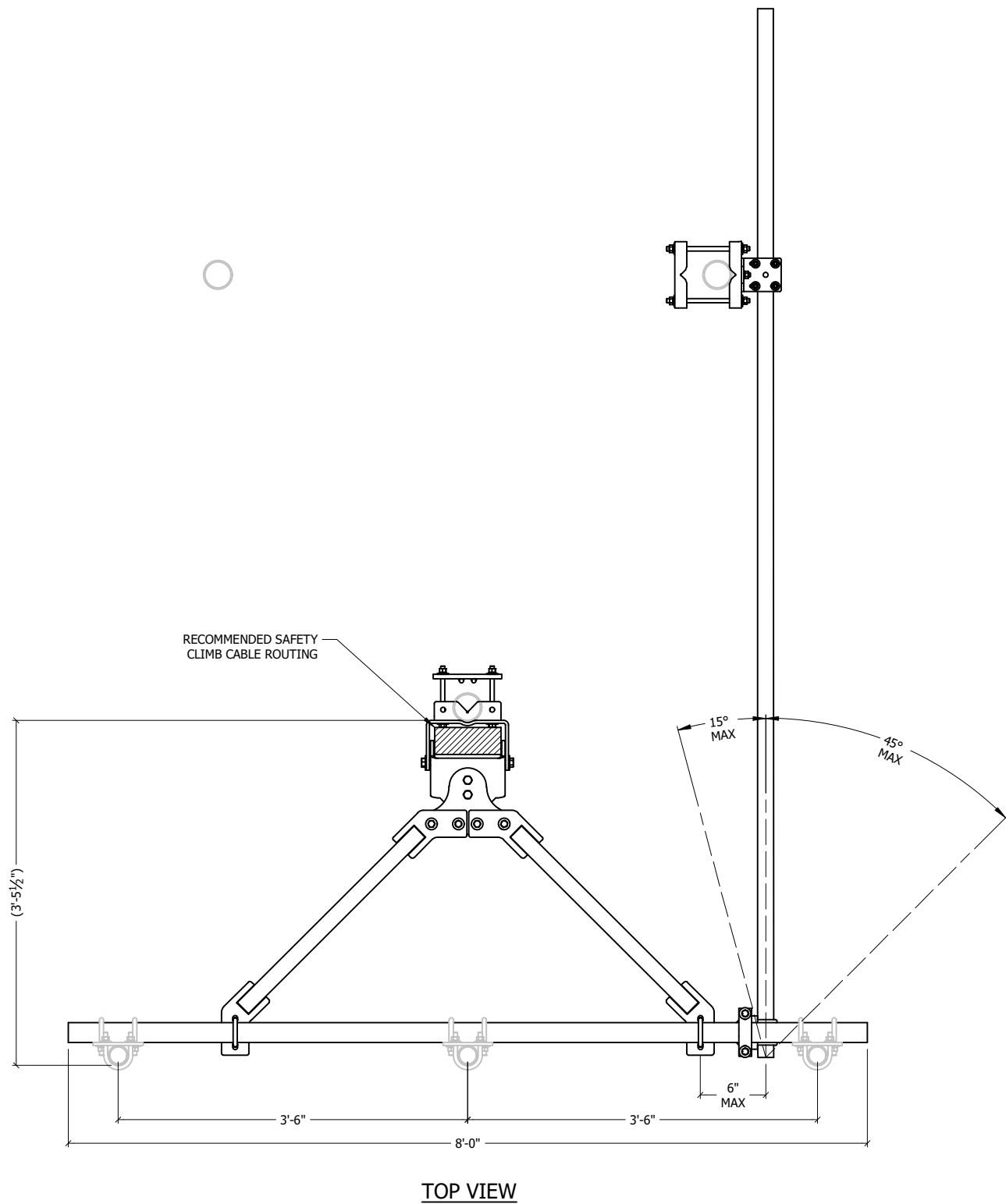

THIS DESIGN AND INFORMATION CONTAINED ON THIS PRINT IS THE PROPERTY OF VALLEY FAB CORPORATION. ANY REPRODUCTION, DUPLICATION OR TRANSFER OF THE PROPRIETARY CONTENT IS PROHIBITED WITHOUT WRITTEN PERMISSION.	
STANDARD TOLERANCES: (UNLESS OTHERWISE NOTED) FRACTIONS ±1/16" DECIMALS ±0.01" ANGLES ±0.5°	 NEWAVE TOWER COMPONENTS, 503-792-3739 10910 PORTLAND RD. BROOKS, OR 97305
TOTAL WT: 287.5 LB	
QTY:	
FINISH:	
JOB #:	

TITLE: 8' PIPE FACE, V-FRAME, ADJ. TAPER, FITS 1-1/2" TO 5" O.D ROUND LEG, SINGLE STIFF-ARM		DRAWN BY: KY	DATE: 8/11/2022	CHK'D BY: -
SERIES: TOWER ANTENNA MOUNT	SHEET: 3 OF 3	DRAWING NO. AM1004-8S		