

REV	BY	DESCRIPTION	DATE
A	KY	SEE MODEL I PROPERTIES/COMMENTS	1/27/2015

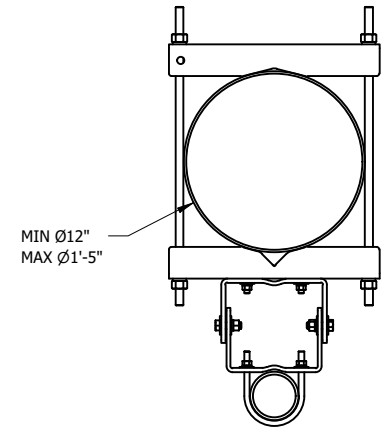
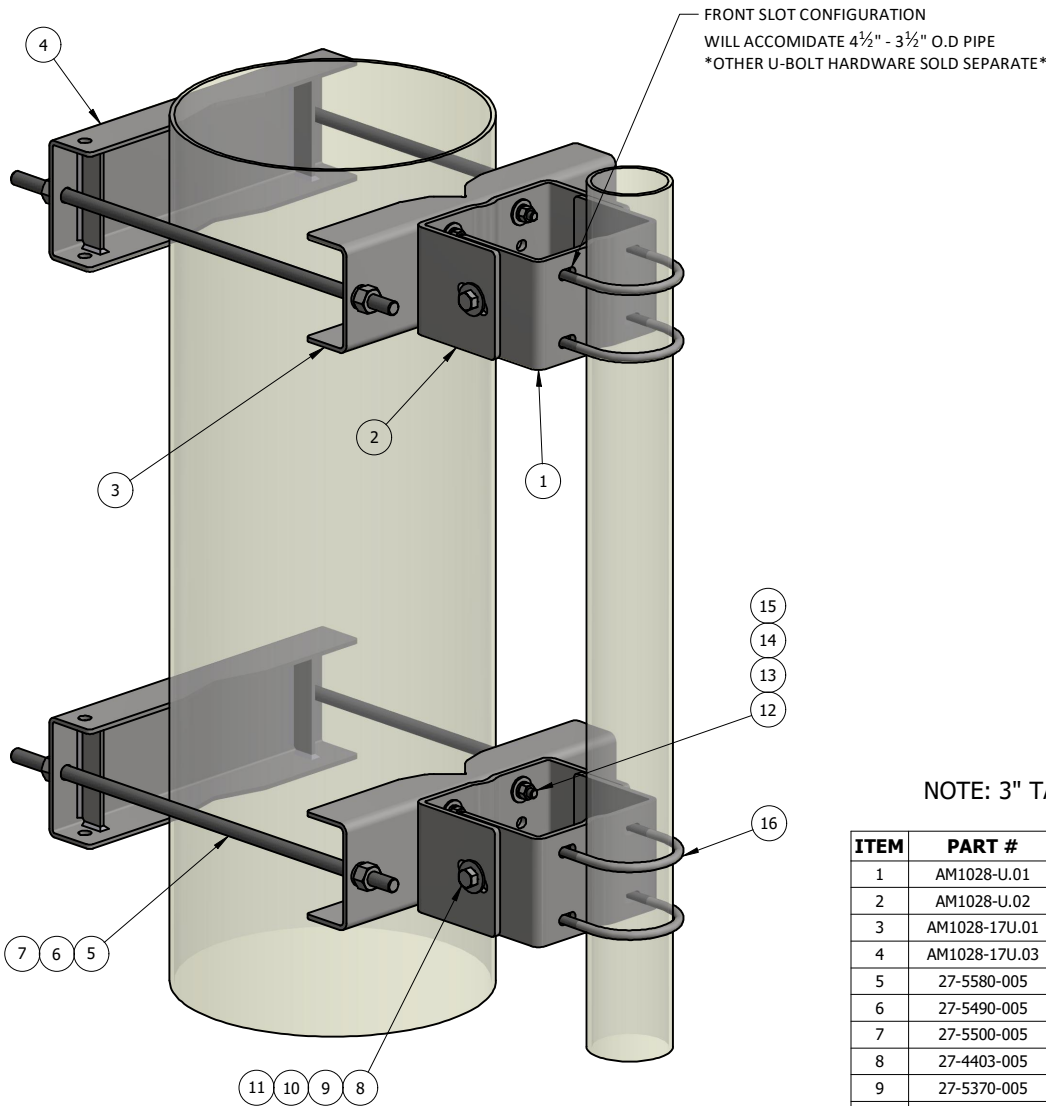

TOP VIEW

NOTE: 3" TAPER ADJUSTMENT AVAILABLE BETWEEN TOP AND BOTTOM BRACKET

ITEM	PART #	QTY	DESCRIPTION	LENGTH	FINISH	UNIT WT
1	AM1028-U.01	2	3/8" PLATE		HDG	12.15
2	AM1028-U.02	2	3/8" PLATE		HDG	12.65
3	AM1028-17U.01	2	INSIDE ADJUSTABLE 17" CHANNEL CLAMP WLM'T		HDG	15.99
4	AM1028-17U.03	2	OUTSIDE ADJUSTABLE 17" CHANNEL CLAMP WLM'T		HDG	17.54
5	27-5580-005	4	3/4" x 28" B7 HDG ALL-THREAD	2'-4"		3.51
6	27-5490-005	8	3/4 HDG LOCK WASHER			0.04
7	27-5500-005	8	3/4 HDG HEAVY HEX NUT			0.21
8	27-4403-005	4	5/8 x 2 GR.5 HDG BOLT			0.27
9	27-5370-005	8	HDG - 5/8" FLAT WASHER, USS			0.08
10	27-5380-005	4	5/8 HDG LOCK WASHER			0.03
11	27-5391-005	4	5/8" HDG HEX NUT			0.08
12	27-4302-005	8	1/2" x 1 3/4" GR.5 HDG BOLT			0.15
13	27-5200-005	16	HDG - 1/2" FLAT WASHER, USS			0.04
14	27-5210-005	8	1/2 HDG LOCK WASHER			0.01
15	27-5222-005	8	1/2 HDG HEX NUT			0.04
16	27-6140-005	4	HDG - 1/2" x 4-5/8" x 6-1/2" U-BOLT ASSEMBLY			1.10

THIS DESIGN AND INFORMATION CONTAINED ON THIS PRINT IS THE PROPERTY OF VALLEY FAB CORPORATION. ANY REPRODUCTION, DUPLICATION OR TRANSFER OF THE PROPRIETARY CONTENT IS PROHIBITED WITHOUT WRITTEN PERMISSION.

STANDARD TOLERANCES:

(UNLESS OTHERWISE NOTED)
FRACTIONS ±1/16"
DECIMALS ±0.01"
ANGLES ±0.5°

NEWAVE
TOWER COMPONENTS. 503-792-3739
10910 PORTLAND RD. BROOKS, OR 97305

TOTAL WT: 141.5 LB

QTY:

FINISH:

JOB #:

TITLE:

ADJUSTABLE TAPERED PIPE MOUNT FOR
FITS 12"-17" O.D. RND OR 12" 90° ANGLE

SERIES: TOWER ANTENNA MOUNT

SHEET: 1 OF 1

DRAWN BY:

KY

DATE:

7/17/2018

CHK'D BY:

-

DRAWING NO.

AM1028-17U