

ITEM	PART #	QTY	DESCRIPTION	LENGTH	FINISH	UNIT WT
1	AM1V.01	1	RIGHT, HD V-FRAME WELDMENT W/ RRU OPTION		HDG	81.85
2	AM1V.09	1	LEFT, HD V-FRAME WELDMENT W/ RRU OPTION		HDG	81.85
3	AM1V.10	2	1/2" PLATE		HDG	9.33
4	AM1V.11	2	HD UNIVERSAL CHANNEL CLAMP WELDMENT		HDG	12.54
5	AM1V.14	2	HD UNIVERSAL CLAMP WELDMENT W/ ADJ. TAPER		HDG	28.05
6	AM1V.17	2	1/2" PLATE		HDG	18.87
7	AM1030-23M.02	2	STIFF ARM HALF CLAMP WELDMENT		HDG	0.92
8	AM1030-23M.03	2	1/4" PLATE		SEE W/O	0.58
9	AM1031.03	4	1/4" PLATE		HDG	1.79
10	AM1031HD.03	4	3/16" PLATE		HDG	1.58
12	P23-126	2	2" STD PIPE	10'-6"	HDG	38.40
13	27-5578-005	4	3/4" x 18" B7 HDG ALL-THREAD	1'-6"		2.25
14	27-5490-005	8	3/4 HDG LOCK WASHER			0.04
15	27-5501-005	8	3/4" HDG HEX NUT			0.14
16	27-4404-005	10	5/8 x 2 1/4 GR.5 HDG BOLT			0.29
17	27-4403-005	10	5/8 x 2 GR.5 HDG BOLT			0.27
18	27-5370-005	10	HDG - 5/8" FLAT WASHER, USS			0.08
19	27-5380-005	20	5/8 HDG LOCK WASHER			0.03
20	27-5391-005	20	5/8" HDG HEX NUT			0.08
21	TR12-10	4	1/2" x 10" A36 HDG ALL-THREAD	10"		0.56
22	27-4310-005	4	GALV. 1/2" x 4" GR.5 FULL THREADED BOLT			0.27
23	27-4300-005	4	1/2" x 1 1/4" GR.5 HDG BOLT			0.12
24	27-5200-005	16	HDG - 1/2" FLAT WASHER, USS			0.04
25	27-5210-005	16	1/2 HDG LOCK WASHER			0.01
26	27-5222-005	16	1/2 HDG HEX NUT			0.04
27	27-6080-005	8	GALV. 1/2" x 3" x 5" GR-5 U-BOLT ASSEMBLY			0.89
28	27-6050-005	8	GALV. 3/8" x 2-1/2" x 4" U-BOLT ASSEMBLY			0.40
29	P278-174	2	2 1/2" STD PIPE	14'-6"	HDG	84.09

THIS DESIGN AND INFORMATION CONTAINED ON THIS PRINT IS THE PROPERTY OF VALLEY FAB CORPORATION. ANY REPRODUCTION, DUPLICATION OR TRANSFER OF THE PROPRIETARY CONTENT IS PROHIBITED WITHOUT WRITTEN PERMISSION.

STANDARD TOLERANCES:
(UNLESS OTHERWISE NOTED)
FRACTIONS ±1/16"
DECIMALS ±0.01"
ANGLES ±0.5°

NEWAVE
TOWER COMPONENTS, 503-792-3739
10910 PORTLAND RD. BROOKS, OR 97305

TOTAL WT: 597.3 LB

QTY:

FINISH:

JOB #:

TITLE:
**14'-6" FACE, V-FRAME, ADJ. TAPER, DBL STIFF-ARM
FITS 1-1/2" TO 10-1/2" O.D ROUND LEG**

SERIES: TOWER ANTENNA MOUNT

SHEET: 1 OF 3

DRAWN BY: DATE: CHK'D BY:
KY 3/29/2021 -

DRAWING NO. AM1V14HD

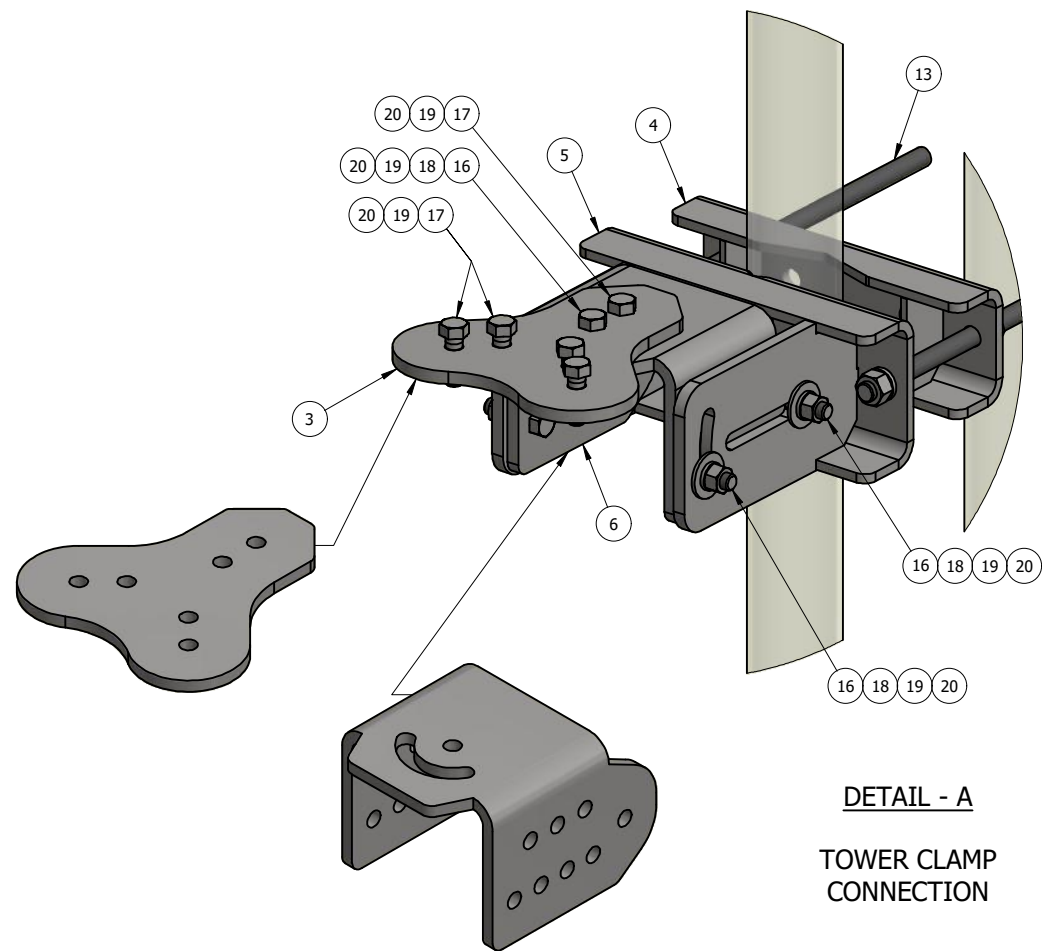

DETAIL - A
TOWER CLAMP CONNECTION

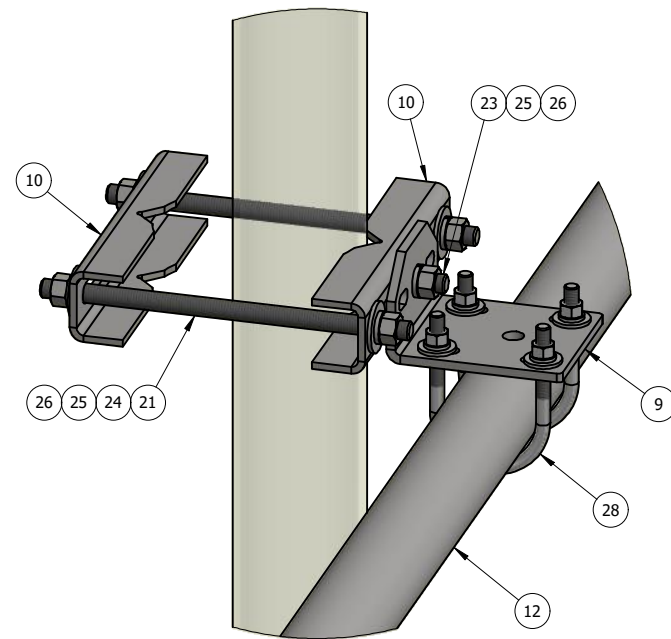

DETAIL - B
STIFF ARM
TOWER LEG
CONNECTION

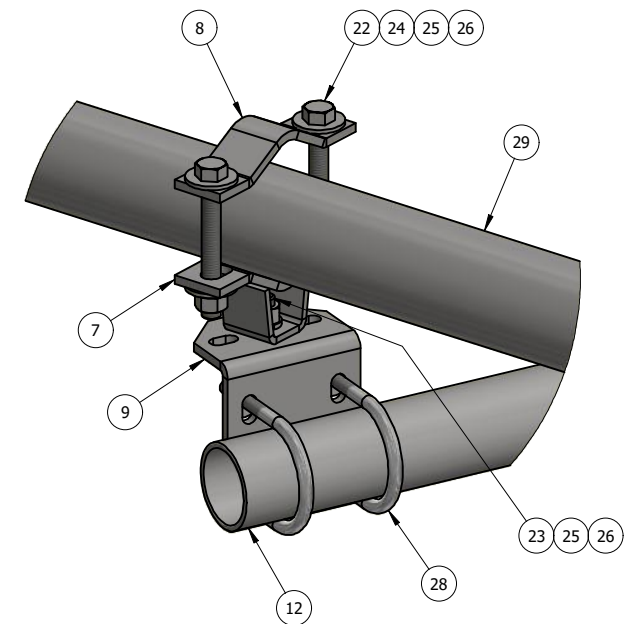

DETAIL - C
STIFF ARM
PIPE FACE
CONNECTION

ITEM	PART #	QTY	DESCRIPTION	LENGTH	FINISH	UNIT WT
1	AM1V.01	1	RIGHT, HD V-FRAME WELDMENT W/ RRU OPTION		HDG	81.85
2	AM1V.09	1	LEFT, HD V-FRAME WELDMENT W/ RRU OPTION		HDG	81.85
3	AM1V.10	2	1/2" PLATE		HDG	9.33
4	AM1V.11	2	HD UNIVERSAL CHANNEL CLAMP WELDMENT		HDG	12.54
5	AM1V.14	2	HD UNIVERSAL CLAMP WELDMENT W/ ADJ. TAPER		HDG	28.05
6	AM1V.17	2	1/2" PLATE		HDG	18.87
7	AM1030-23M.02	2	STIFF ARM HALF CLAMP WELDMENT		HDG	0.92
8	AM1030-23M.03	2	1/4" PLATE		SEE W/O	0.58
9	AM1031.03	4	1/4" PLATE		HDG	1.79
10	AM1031HD.03	4	3/16" PLATE		HDG	1.58
12	P23-126	2	2" STD PIPE	10'-6"	HDG	38.40
13	27-5578-005	4	3/4" x 18" B7 HDG ALL-THREAD	1'-6"		2.25
14	27-5490-005	8	3/4 HDG LOCK WASHER			0.04
15	27-5501-005	8	3/4" HDG HEX NUT			0.14
16	27-4404-005	10	5/8 x 2 1/4 GR.5 HDG BOLT			0.29
17	27-4403-005	10	5/8 x 2 GR.5 HDG BOLT			0.27
18	27-5370-005	10	HDG - 5/8" FLAT WASHER, USS			0.08
19	27-5380-005	20	5/8 HDG LOCK WASHER			0.03
20	27-5391-005	20	5/8" HDG HEX NUT			0.08
21	TR12-10	4	1/2" x 10" A36 HDG ALL-THREAD	10"		0.56
22	27-4310-005	4	GALV. 1/2" x 3" x 5" GR.5 FULL THREADED BOLT			0.27
23	27-4300-005	4	1/2" x 1 1/4" GR.5 HDG BOLT			0.12
24	27-5200-005	16	HDG - 1/2" FLAT WASHER, USS			0.04
25	27-5210-005	16	1/2 HDG LOCK WASHER			0.01
26	27-5222-005	16	1/2 HDG HEX NUT			0.04
27	27-6080-005	8	GALV. 1/2" x 3" x 5" GR-5 U-BOLT ASSEMBLY			0.89
28	27-6050-005	8	GALV. 3/8" x 2-1/2" x 4" U-BOLT ASSEMBLY			0.40
29	P278-174	2	2 1/2" STD PIPE	14'-6"	HDG	84.09

THIS DESIGN AND INFORMATION CONTAINED ON THIS PRINT IS THE PROPERTY OF VALLEY FAB CORPORATION. ANY REPRODUCTION, DUPLICATION OR TRANSFER OF THE PROPRIETARY CONTENT IS PROHIBITED WITHOUT WRITTEN PERMISSION.

STANDARD TOLERANCES:
(UNLESS OTHERWISE NOTED)
FRACTIONS ±1/16"
DECIMALS ±0.01"
ANGLES ±0.5°



TOWER COMPONENTS, 503-792-3739
10910 PORTLAND RD. BROOKS, OR 97305

TOTAL WT: 597.3 LB

QTY:

FINISH:

JOB #:

TITLE:
14'-6" FACE, V-FRAME, ADJ. TAPER, DBL STIFF-ARM
FITS 1-1/2" TO 10-1/2" O.D ROUND LEG

SERIES: TOWER ANTENNA MOUNT SHEET: 2 OF 3

DRAWN BY: KY DATE: 3/29/2021

CHK'D BY: -

DRAWING NO. AM1V14HD

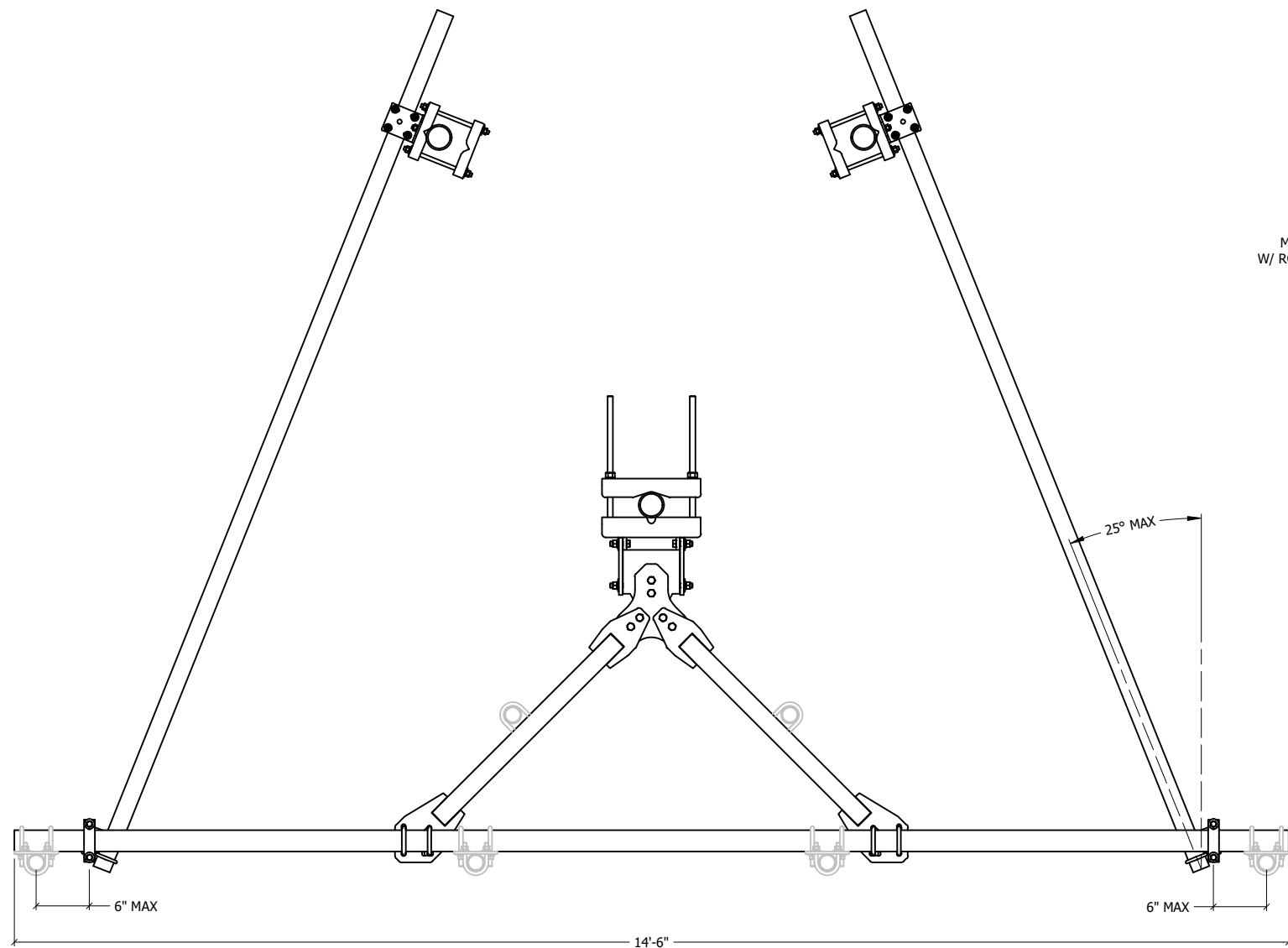

TOP VIEW

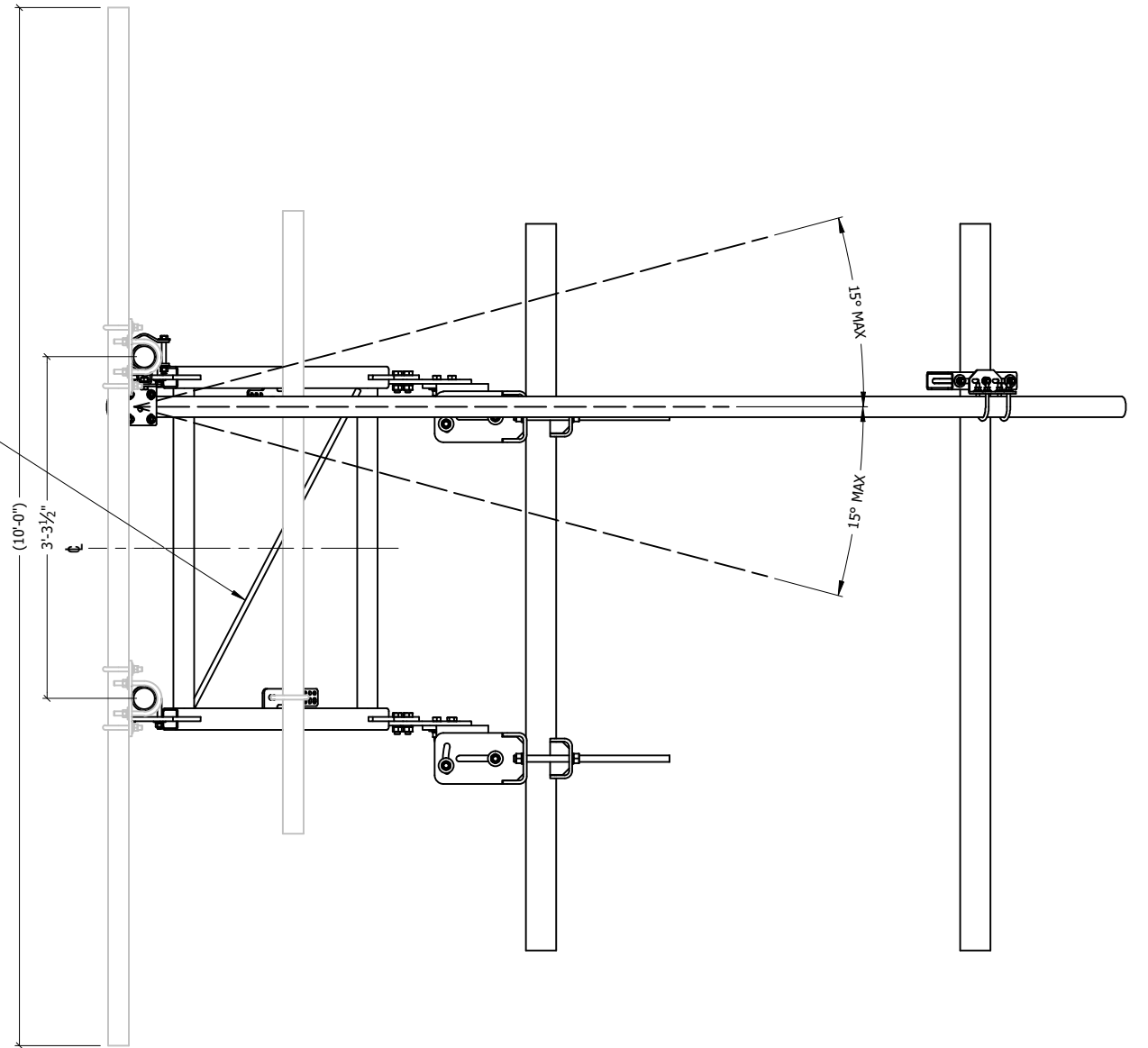

SIDE VIEW

MOUNT MUST BE INSTALLED W/ RODS IN THIS ORIENTATION

<p>THIS DESIGN AND INFORMATION CONTAINED ON THIS PRINT IS THE PROPERTY OF VALLEY FAB CORPORATION. ANY REPRODUCTION, DUPLICATION OR TRANSFER OF THE PROPRIETARY CONTENT IS PROHIBITED WITHOUT WRITTEN PERMISSION.</p>	
<p>STANDARD TOLERANCES: (UNLESS OTHERWISE NOTED) FRACTIONS ±1/16" DECIMALS ±0.01" ANGLES ±0.5°</p>	<p>NEWAVE TOWER COMPONENTS, 503-792-3739 10910 PORTLAND RD. BROOKS, OR 97305</p>
<p>TOTAL WT: 597.3 LB</p>	<p>QTY:</p>
<p>FINISH:</p>	<p>JOB #:</p>

<p>TITLE: 14'-6" FACE, V-FRAME, ADJ. TAPER, DBL STIFF-ARM FITS 1-1/2" TO 10-1/2" O.D ROUND LEG</p>	<p>DRAWN BY: KY DATE: 3/29/2021</p>	<p>CHK'D BY: -</p>
<p>SERIES: TOWER ANTENNA MOUNT</p>	<p>SHEET: 3 OF 3</p>	<p>DRAWING NO. AM1V14HD</p>