

REV	BY	DESCRIPTION	DATE
A	JG	SEE MODEL I PROPERTIES/COMMENTS	4/7/2020

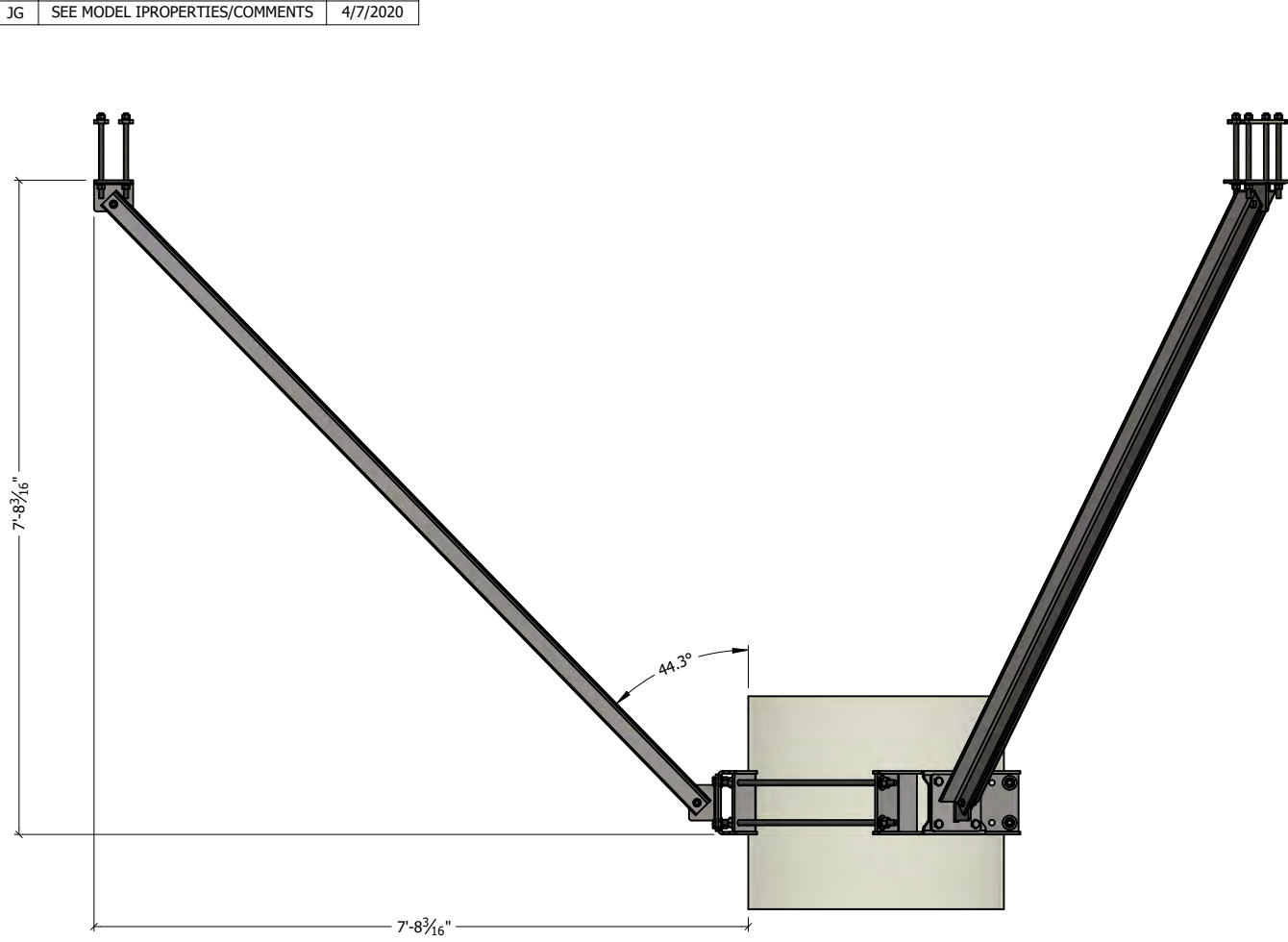

SIDE VIEW

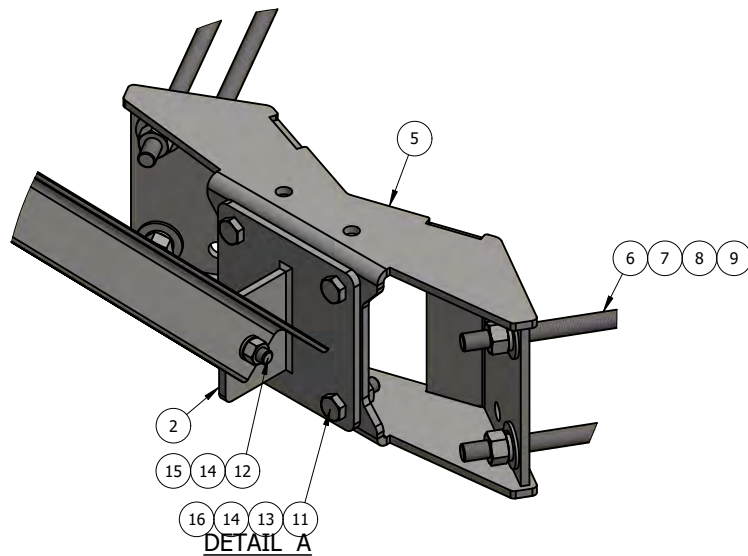
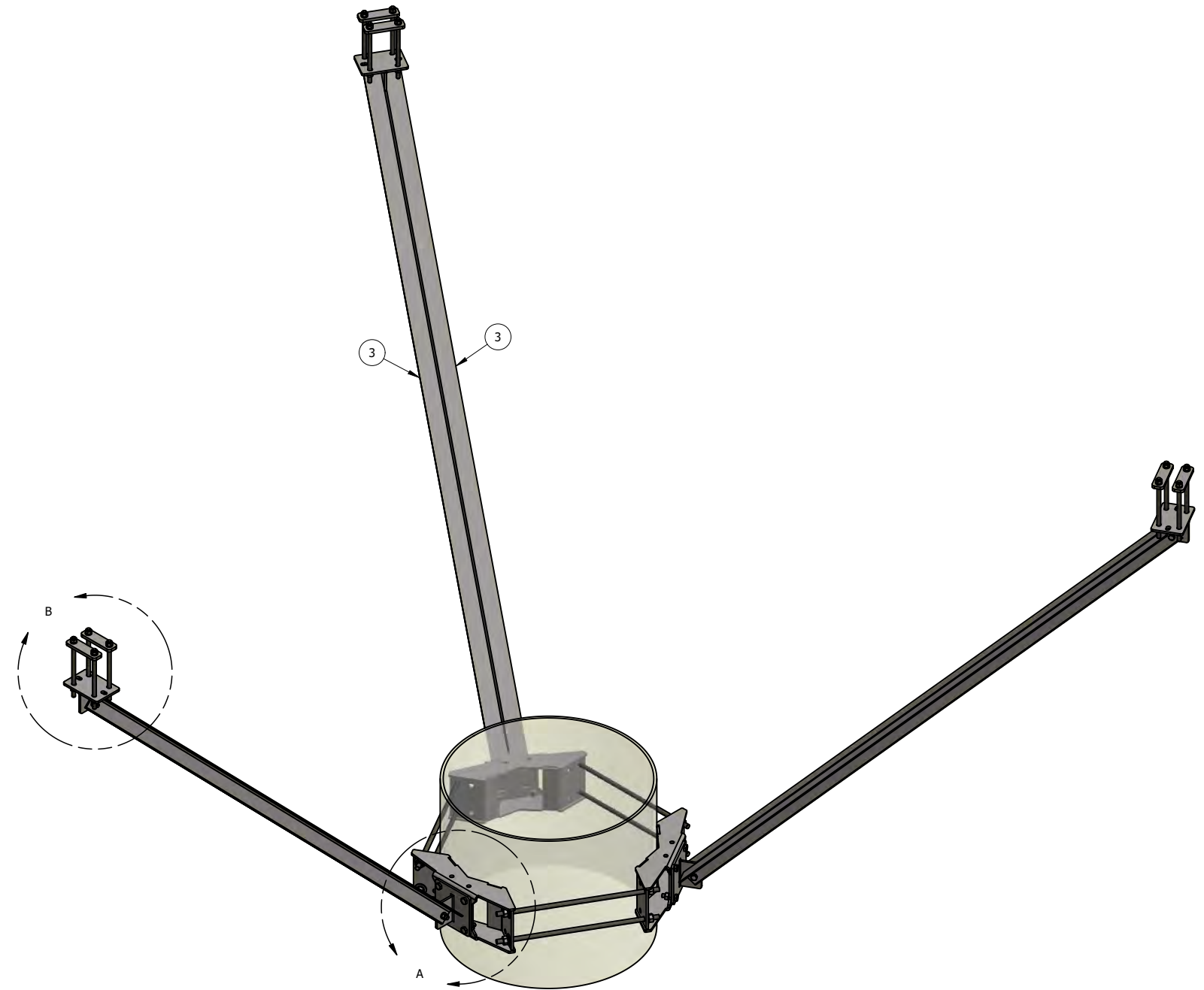

DETAIL A

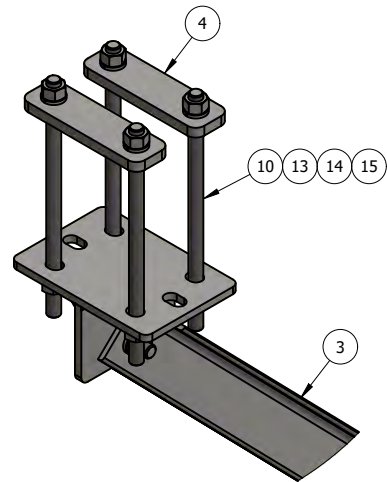

DETAIL - B

NOTE:  
 1. FIELD PREP ANGLE TO FIT  
 2. FILED CUT ALL THREAD TO FIT

THIS DESIGN AND INFORMATION CONTAINED ON THIS PRINT IS THE PROPERTY OF VALLEY FAB CORPORATION. ANY REPRODUCTION, DUPLICATION OR TRANSFER OF THE PROPRIETARY CONTENT IS PROHIBITED WITHOUT WRITTEN PERMISSION.

**STANDARD TOLERANCES:**  
 (UNLESS OTHERWISE NOTED)  
 FRACTIONS ±1/16"  
 DECIMALS ±0.01"  
 ANGLES ±0.5°

**NEWAVE**  
 TOWER COMPONENTS, 503-792-3739  
 10910 PORTLAND RD. BROOKS, OR 97305

TOTAL WT: 520.25 LB  
 QTY:  
 FINISH:  
 JOB #:

ITEM	PART #	QTY	DESCRIPTION	LENGTH	FINISH	UNIT WT
1	LPS30-20.01	3	LOW PROFILE TOP BRACKET WELDMENT		HDG	6.68
2	LPS.01	3	LOWER MOUNTING BRACKET		HDG	8.63
3	LPS.05	6	L3x3x1/4"	10'	HDG	49.40
4	LP.01	6	1/2" PLATE			1.81
5	M1236-3.01	3	UNIV. 12" TO 36" OD RING MOUNT WELDMENT		HDG	38.96
6	27-5580-005	6	3/4" x 28" B7 HDG ALL-THREAD	2'-4"		3.51
7	27-5481-005	12	3/4 A36 HDG FLAT WASHER			0.11
8	27-5490-005	12	3/4 HDG LOCK WASHER			0.04
9	27-5500-005	12	3/4 HDG HEAVY HEX NUT			0.21
10	TR58-12	12	5/8" x 12" A36 HDG ALL-THREAD	1'		1.04
11	27-5440-005	12	5/8" x 2 1/4" A325 HDG BOLT			0.30
12	27-4403-005	6	5/8" x 2" GR.5 HDG BOLT			0.27
13	27-5370-005	24	5/8 A36 HDG FLAT WASHER			0.08
14	27-5380-005	42	5/8 HDG LOCK WASHER			0.03
15	27-5391-005	30	5/8" HDG HEX NUT			0.08
16	27-5390-005	12	5/8" HDG HEAVY HEX NUT			0.13

TITLE:  
**LOW PROFILE STIFFENER 3-SECTOR W/  
 10'-0" KICKERS & 12" TO 36" RING MOUNT**  
 SERIES: MONOPOLE MOUNTING SHEET: 1 OF 1

DRAWN BY: JG DATE: 7/17/2018 CHK'D BY: KY  
 DRAWING NO. LPS30-25