

ANTENNA PIPE
SOLD SEPARATE

CROSSOVER KITS
SOLD SEPARATE

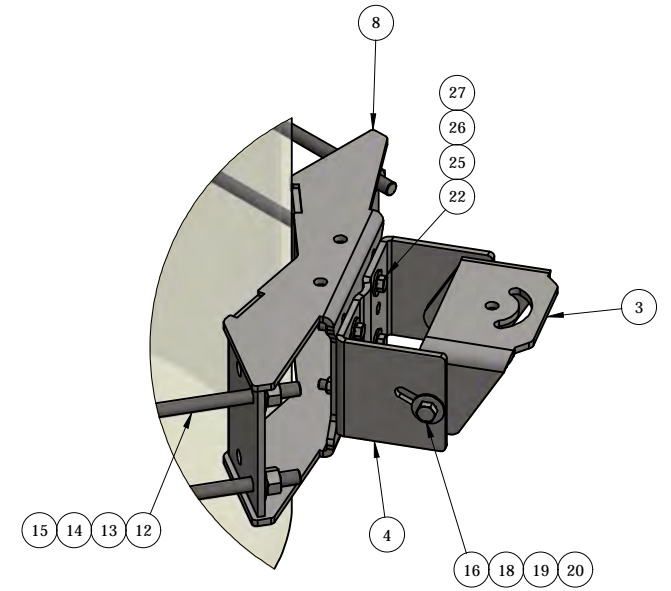
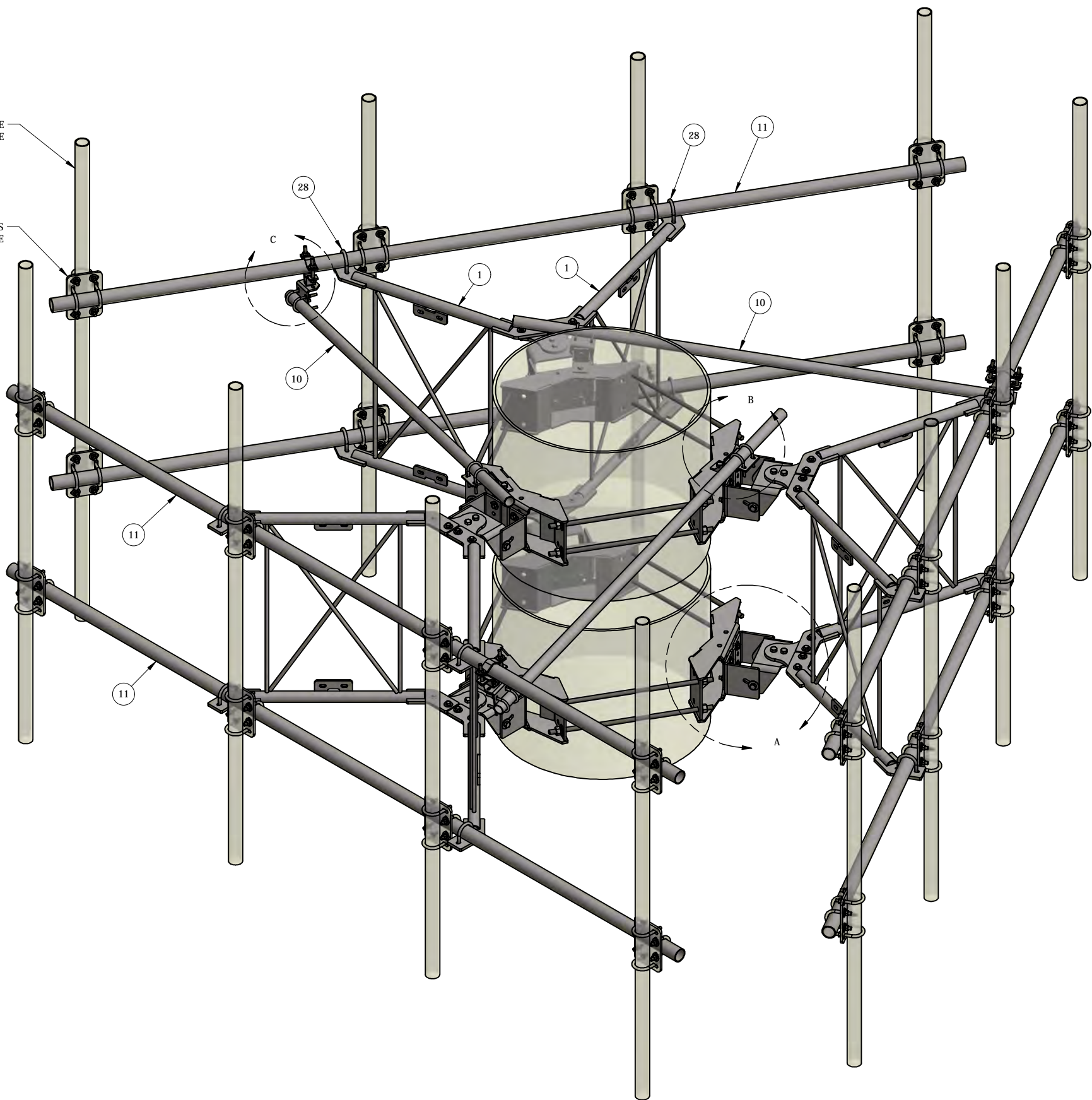

DETAIL - A

ITEM	PART #	QTY	DESCRIPTION	LENGTH	FINISH	UNIT WT
1	AM1004.01	6	V-FRAME WELDMENT		HDG	46.58
2	AM1004.07	6	1/2" PLATE		BARE	7.39
3	AM1004.08	6	3/8 PLATE		BARE	8.91
4	AM1028-U.02	6	3/8" PLATE		HDG	12.65
5	AM1030-23M.02	3	STIFF ARM HALF CLAMP WELDMENT		HDG	0.92
6	AM1030-23M.03	3	1/4" PLATE		SEE W/O	0.58
7	AM1031.03	6	1/4" PLATE		HDG	1.79
8	M1236-3.01	6	UNIV. 12" TO 36" OD RING MOUNT WELDMENT		HDG	38.96
9	MCMX.04	3	CHAIN MOUNT CLEVIS BOLT ATTACHMENT		HDG	1.39
10	P178-84	3	1 1/2" STD PIPE	7'	HDG	19.04
11	P23-156	6	2" STD PIPE	13'	HDG	47.54
12	27-5580-005	12	3/4" x 28" B7 HDG ALL-THREAD	2'-4"		3.51
13	27-5481-005	24	3/4 A36 HDG FLAT WASHER			0.11
14	27-5490-005	24	3/4 HDG LOCK WASHER			0.04
15	27-5500-005	24	3/4 HDG HEAVY HEX NUT			0.21
16	27-4403-005	24	5/8 x 2 GR.5 HDG BOLT			0.27
17	27-4402-005	3	5/8" x 1 3/4" GR.5 HDG BOLT			0.25
18	27-5370-005	30	5/8 A36 HDG FLAT WASHER			0.08
19	27-5380-005	27	5/8 HDG LOCK WASHER			0.03
20	27-5391-005	27	5/8" HDG HEX NUT			0.08
21	27-4310-005	6	GALV. 1/2" x 4" GR.5 FULL THREADED BOLT			0.27
22	27-4303-005	48	1/2" x 2" GR.5 HDG BOLT			0.16
23	27-4301-005	3	1/2" x 1 1/2" GR.5 HDG BOLT			0.13
24	27-4300-005	3	1/2" x 1 1/4" GR.5 HDG BOLT			0.12
25	27-5200-005	84	1/2 A36 HDG FLAT WASHER			0.04
26	27-5210-005	60	1/2 HDG LOCK WASHER			0.01
27	27-5222-005	60	1/2 HDG HEX NUT			0.04
28	27-6060-005	12	HDG - 1/2" x 2-1/2" x 4" U-BOLT ASSEMBLY		HDG	0.76
29	27-6040-005	12	GALV. 3/8" x 2" x 4" U-BOLT ASSEMBLY			0.38

THIS DESIGN AND INFORMATION CONTAINED ON THIS PRINT IS THE PROPERTY OF VALLEY FAB CORPORATION. ANY REPRODUCTION, DUPLICATION OR TRANSFER OF THE PROPRIETARY CONTENT IS PROHIBITED WITHOUT WRITTEN PERMISSION.

STANDARD TOLERANCES:
(UNLESS OTHERWISE NOTED)
FRACTIONS - 1/16"
DECIMALS - 0.01"
ANGLES - 0.5°

NEWAVE
TOWER COMPONENTS, 503-792-3739
10910 PORTLAND RD. BROOKS, OR 97305

TOTAL WT: 1142.55 LB
QTY:
FINISH:
JOB #:

TITLE: 13'-0" PIPE FACE, V-FRAME, ADJ. TAPER, FITS 12" TO 36" O.D MONOPOLE

SERIES: MONOPOLE MOUNTING SHEET: 1 OF 3

DRAWN BY: KY DATE: 1/17/2023
CHK'D BY: -
DRAWING NO. M36-AM1004-13S

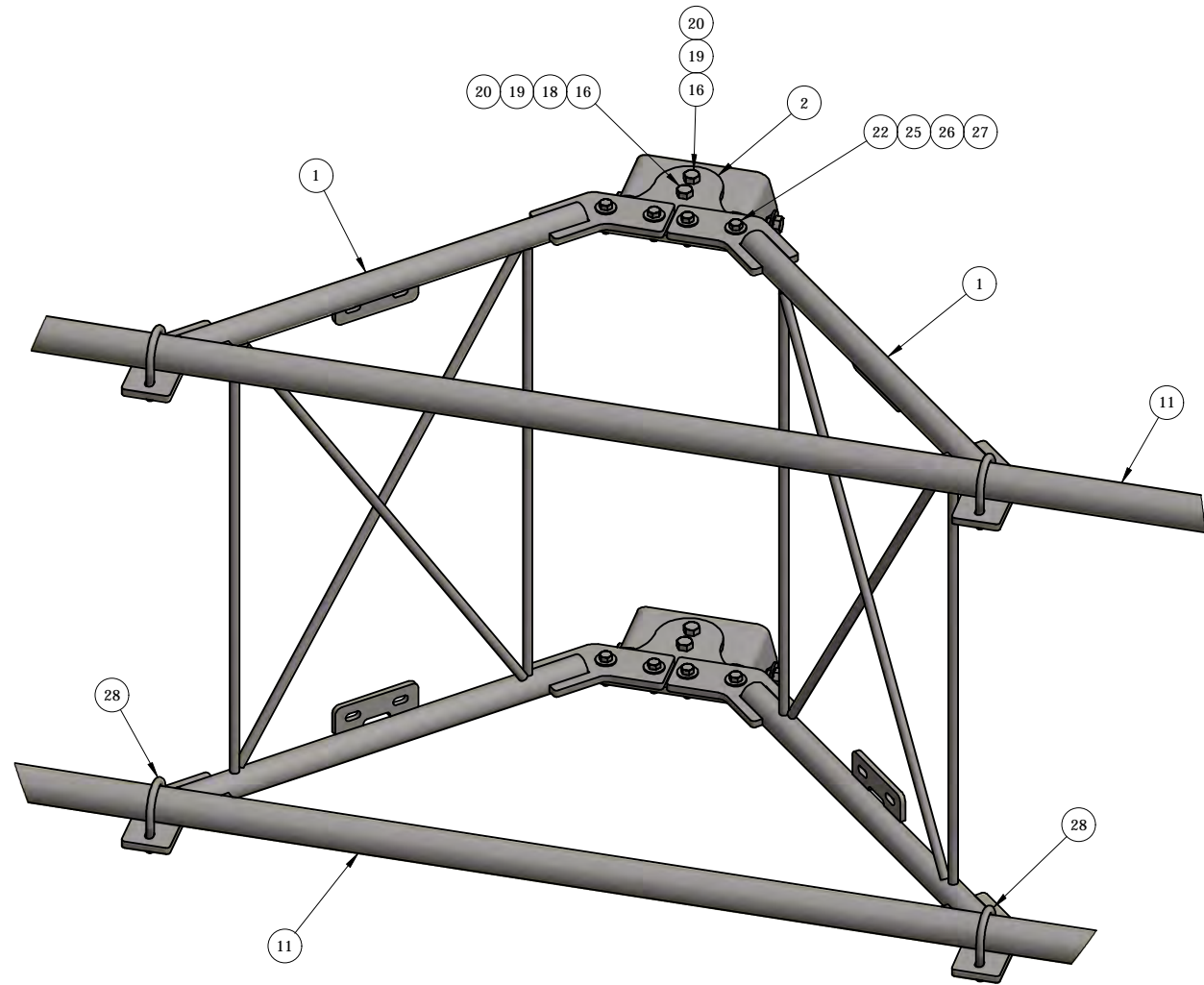

V-FRAME - DETAIL

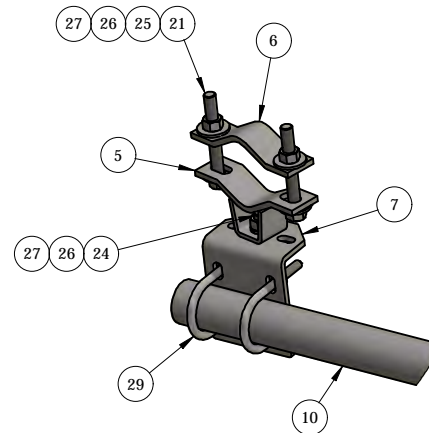

DETAIL - C
STIFF ARM
PIPE FACE
CONNECTION

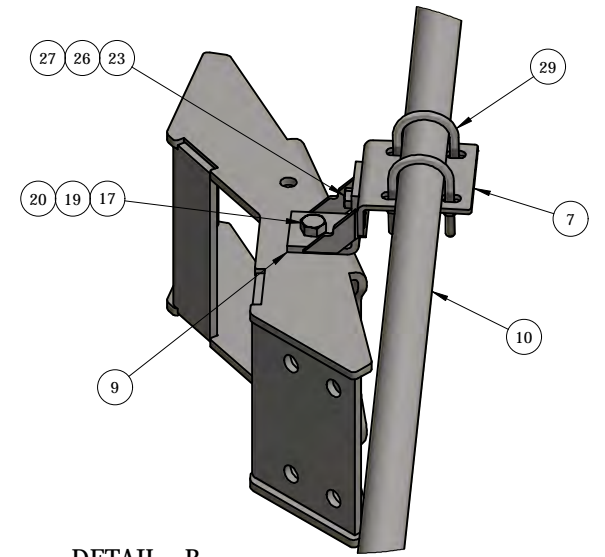

DETAIL - B
STIFF ARM
RING MOUNT
CONNECTION

ITEM	PART #	QTY	DESCRIPTION	LENGTH	FINISH	UNIT WT
1	AM1004.01	6	V-FRAME WELDMENT		HDG	46.58
2	AM1004.07	6	1/2" PLATE		BARE	7.39
3	AM1004.08	6	3/8 PLATE		BARE	8.91
4	AM1028-U.02	6	3/8" PLATE		HDG	12.65
5	AM1030-23M.02	3	STIFF ARM HALF CLAMP WELDMENT		HDG	0.92
6	AM1030-23M.03	3	1/4" PLATE		SEE W/O	0.58
7	AM1031.03	6	1/4" PLATE		HDG	1.79
8	M1236-3.01	6	UNIV. 12" TO 36" OD RING MOUNT WELDMENT		HDG	38.96
9	MCMX.04	3	CHAIN MOUNT CLEVIS BOLT ATTACHMENT		HDG	1.39
10	P178-84	3	1 1/2" STD PIPE	7'	HDG	19.04
11	P23-156	6	2" STD PIPE	13'	HDG	47.54
12	27-5580-005	12	3/4" x 28" B7 HDG ALL-THREAD	2'-4"		3.51
13	27-5481-005	24	3/4 A36 HDG FLAT WASHER			0.11
14	27-5490-005	24	3/4 HDG LOCK WASHER			0.04
15	27-5500-005	24	3/4 HDG HEAVY HEX NUT			0.21
16	27-4403-005	24	5/8 x 2 GR.5 HDG BOLT			0.27
17	27-4402-005	3	5/8" x 1 3/4" GR.5 HDG BOLT			0.25
18	27-5370-005	30	5/8 A36 HDG FLAT WASHER			0.08
19	27-5380-005	27	5/8 HDG LOCK WASHER			0.03
20	27-5391-005	27	5/8" HDG HEX NUT			0.08
21	27-4310-005	6	GALV. 1/2" x 4" GR.5 FULL THREADED BOLT			0.27
22	27-4303-005	48	1/2" x 2" GR.5 HDG BOLT			0.16
23	27-4301-005	3	1/2" x 1 1/2" GR.5 HDG BOLT			0.13
24	27-4300-005	3	1/2" x 1 1/4" GR.5 HDG BOLT			0.12
25	27-5200-005	84	1/2 A36 HDG FLAT WASHER			0.04
26	27-5210-005	60	1/2 HDG LOCK WASHER			0.01
27	27-5222-005	60	1/2 HDG HEX NUT			0.04
28	27-6060-005	12	HDG - 1/2" x 2-1/2" x 4" U-BOLT ASSEMBLY		HDG	0.76
29	27-6040-005	12	GALV. 3/8" x 2" x 4" U-BOLT ASSEMBLY			0.38

THIS DESIGN AND INFORMATION CONTAINED ON THIS PRINT IS THE PROPERTY OF VALLEY FAB CORPORATION. ANY REPRODUCTION, DUPLICATION OR TRANSFER OF THE PROPRIETARY CONTENT IS PROHIBITED WITHOUT WRITTEN PERMISSION.

STANDARD TOLERANCES:
(UNLESS OTHERWISE NOTED)
FRACTIONS - 1/16"
DECIMALS - 0.01"
ANGLES - 0.5°

NEWAVE
TOWER COMPONENTS, 503-792-3739
10910 PORTLAND RD. BROOKS, OR 97305

TOTAL WT: 1142.55 LB
QTY:
FINISH:
JOB #:

TITLE: 13'-0" PIPE FACE, V-FRAME, ADJ. TAPER, FITS 12" TO 36" O.D MONOPOLE

SERIES: MONOPOLE MOUNTING SHEET: 2 OF 3

DRAWN BY: KY DATE: 1/17/2023 CHK'D BY: -
DRAWING NO. M36-AM1004-13S

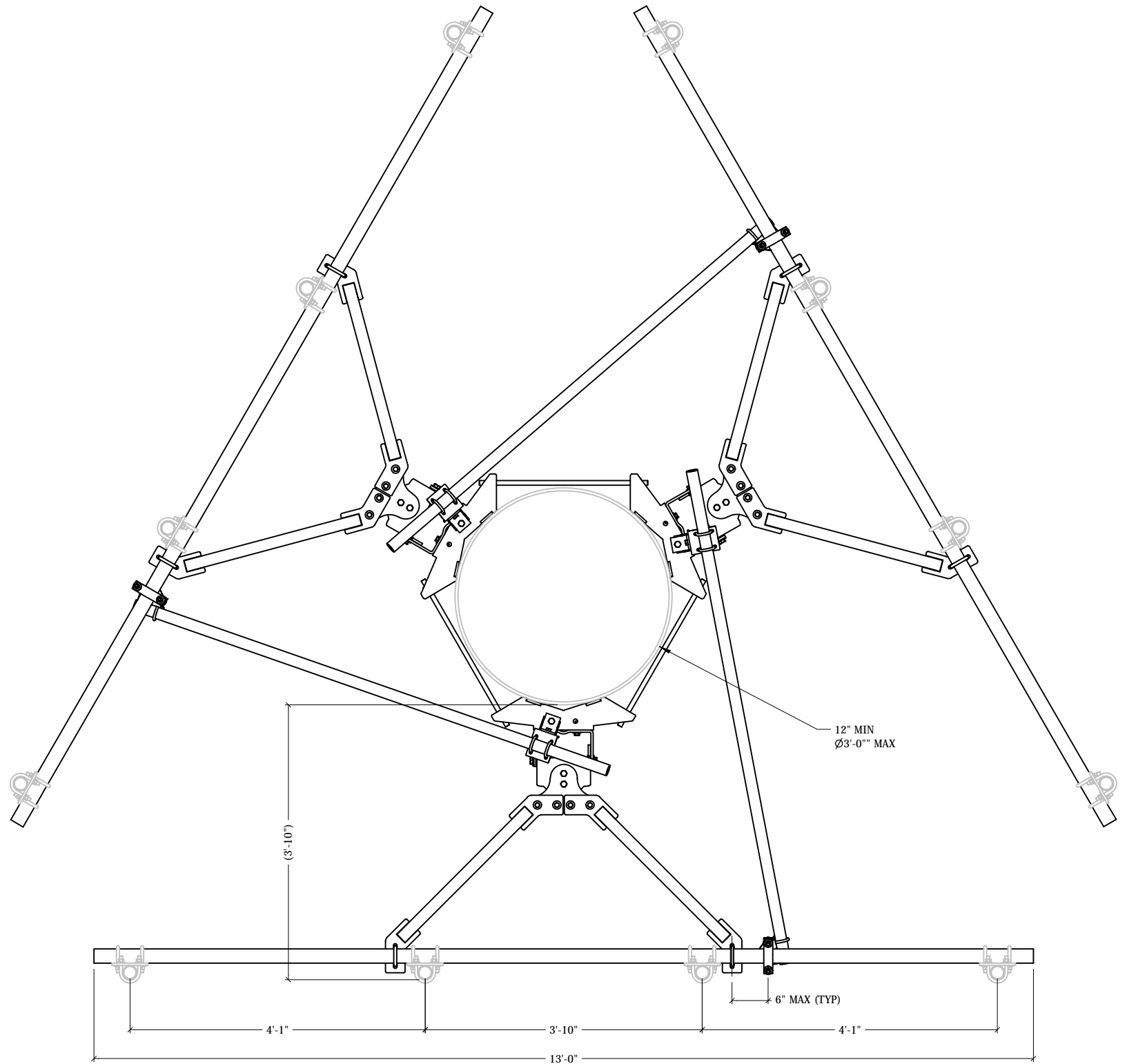

TOP VIEW

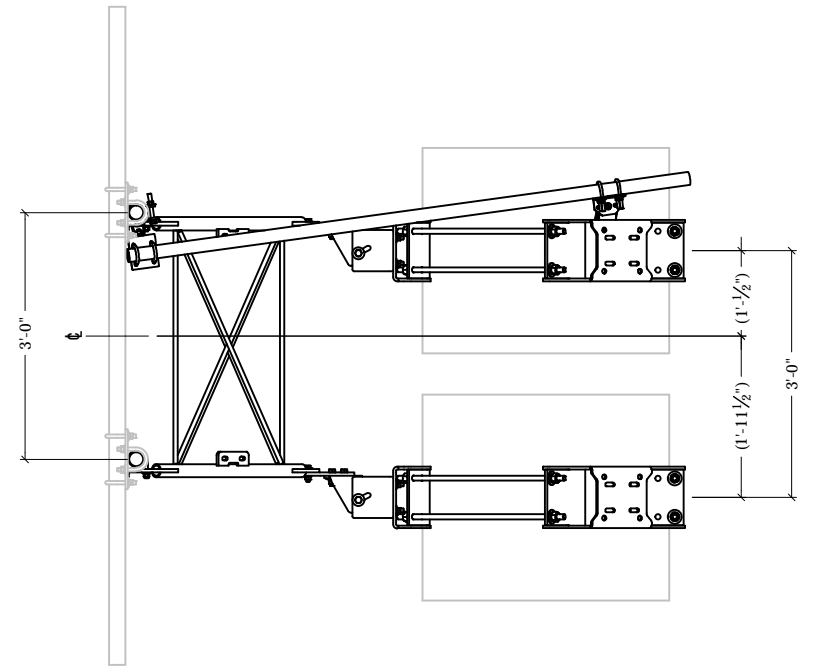

SIDE VIEW

<p>THIS DESIGN AND INFORMATION CONTAINED ON THIS PRINT IS THE PROPERTY OF VALLEY FAB CORPORATION. ANY REPRODUCTION, DUPLICATION OR TRANSFER OF THE PROPRIETARY CONTENT IS PROHIBITED WITHOUT WRITTEN PERMISSION.</p>	
<p>STANDARD TOLERANCES: (UNLESS OTHERWISE NOTED) FRACTIONS - 1/16" DECIMALS - 0.01" ANGLES - 0.5°</p>	<p>NEWAVE TOWER COMPONENTS, 503-792-3739 10910 PORTLAND RD. BROOKS, OR 97305</p>
<p>TOTAL WT: 1142.55 LB</p>	<p>QTY:</p>
<p>FINISH:</p>	<p>JOB #:</p>

<p>TITLE: 13'-0" PIPE FACE, V-FRAME, ADJ. TAPER, FITS 12" TO 36" O.D MONOPOLE</p>	<p>DRAWN BY: KY DATE: 1/17/2023</p>	<p>CHK'D BY: -</p>
<p>SERIES: MONOPOLE MOUNTING</p>	<p>SHEET: 3 OF 3</p>	<p>DRAWING NO. M36-AM1004-13S</p>