

REV	BY	DESCRIPTION	DATE
A	RAJ	SEE MODEL IPROPERTIES/ COMMENTS	5/20/2021

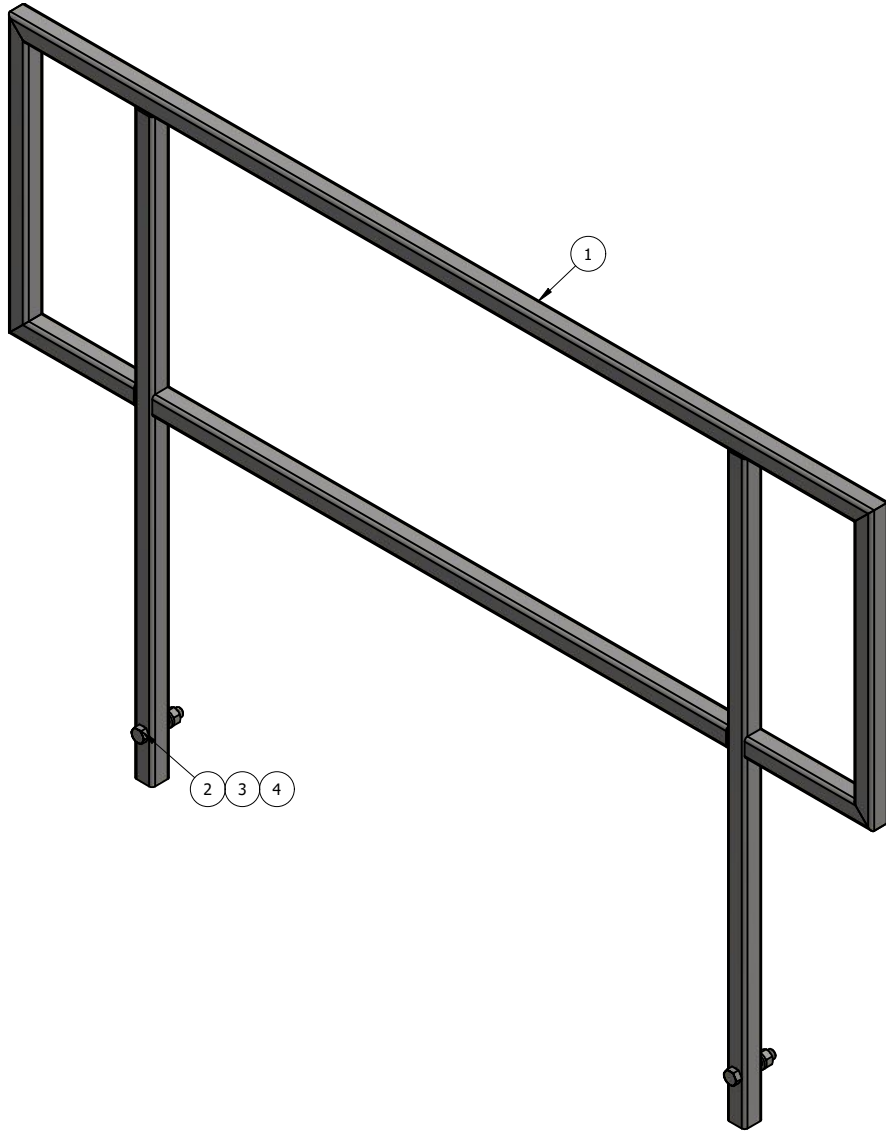

ITEM	PART #	QTY	DESCRIPTION	LENGTH	FINISH	UNIT WT
1	AFHK-6M.01	1	HANDRAIL WELDMENT FOR 6' PLATFORM CHANNEL		HDG	47.83
2	27-4408-005	2	5/8" x 3" GR.5 HDG BOLT			0.36
3	27-5380-005	2	5/8 HDG LOCK WASHER			0.03
4	27-5391-005	2	5/8" HDG HEX NUT			0.08

THIS DESIGN AND INFORMATION CONTAINED ON THIS PRINT IS THE PROPERTY OF VALLEY FAB CORPORATION. ANY REPRODUCTION, DUPLICATION OR TRANSFER OF THE PROPRIETARY CONTENT IS PROHIBITED WITHOUT WRITTEN PERMISSION.

STANDARD TOLERANCES:

(UNLESS OTHERWISE NOTED)

FRACTIONS ±1/16"
 DECIMALS ±0.01"
 ANGLES ±0.5°

NEW WAVE
 TOWER COMPONENTS. 503-792-3739
 10910 PORTLAND RD. BROOKS, OR 97305

TOTAL WT: 48.75 LB

QTY:

FINISH: HDG

JOB #:

TITLE:	STANDARD HANDRAIL ASSEMBLY FOR 6' PLATFORM CHANNEL		DRAWN BY:	RJ	DATE:	5/29/2020	CHK'D BY:	CJW
SERIES:	PLATFORM	SHEET:	1 OF 1		AFHK-6M			