

**DETAIL - B**

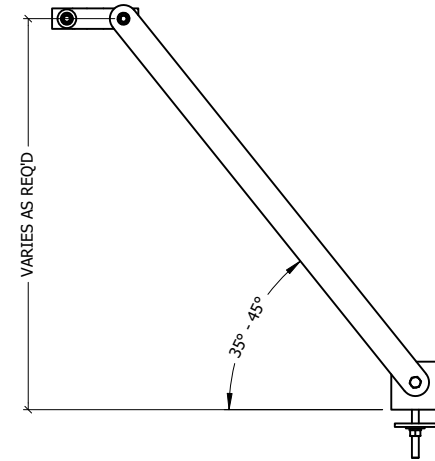

**FRONT VIEW**

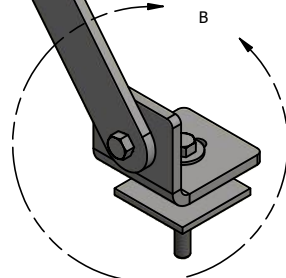

ITEM	PART #	QTY	DESCRIPTION	LENGTH	FINISH	UNIT WT
1	AMCS-3.01	1	1/2" PLATE		SEE W/O	1.26
2	ICBK.01	1	3/8" PLATE		HDG	2.43
3	ICBK-3.01	1	3/8" PLATE		HDG	7.51
4	SFW3-1116G	1	1/4" PLATE		HDG	0.61
5	27-4310-005	1	GALV. 1/2" x 4" GR.5 FULL THREADED BOLT			0.27
6	27-4302-005	1	1/2" x 1 3/4" GR.5 HDG BOLT			0.15
7	27-5200-005	2	1/2 A36 HDG FLAT WASHER			0.04
8	27-5210-005	3	1/2 HDG LOCK WASHER			0.01
9	27-5222-005	3	1/2 HDG HEX NUT			0.04
10	27-6100-005	1	GALV. 1/2" x 3 5/8" x 6" U-BOLT ASS'Y, 2-1/2" THD			1.02

THIS DESIGN AND INFORMATION CONTAINED ON THIS PRINT IS THE PROPERTY OF VALLEY FAB CORPORATION. ANY REPRODUCTION, DUPLICATION OR TRANSFER OF THE PROPRIETARY CONTENT IS PROHIBITED WITHOUT WRITTEN PERMISSION.

**STANDARD TOLERANCES:**  
 (UNLESS OTHERWISE NOTED)  
 FRACTIONS ±1/16"  
 DECIMALS ±0.01"  
 ANGLES ±0.5°

**NEWAVE**  
 TOWER COMPONENTS. 503-792-3739  
 10910 PORTLAND RD. BROOKS, OR 97305

TOTAL WT: 13.5 LB  
 QTY:  
 FINISH: HDG  
 JOB #:

TITLE: 3' DIAGONAL BRACE KIT FOR ICE CANOPY  
 SERIES: ICE CANOPY SHEET: 1 OF 1  
 DRAWN BY: RJ DATE: 10/18/2021 CHK'D BY: KY  
 DRAWING NO. ICBK-3