

ITEM	PART #	QTY	DESCRIPTION	FINISH	UNIT WT
1	LPSRK.01	1	L6x4x1/2"	HDG	20.04
2	LPSRK.02	1	L6x4x1/2"	HDG	10.70
3	LPSRK.03	1	L4x3x1/4"	HDG	1.88
4	LPSRK.04	1	L4x3x1/4"	HDG	1.88
5	LPSRK.05	2	L3x3x1/4"	HDG	39.49
6	AMCS-3.01	2	1/2" PLATE	SEE W/O	1.26
7	TR12-8	4	1/2" x 8" A36 HDG ALL-THREAD		0.44
8	27-4320-005	4	GALV. 1/2" x 7" GR.5 FULL THREADED BOLT		0.44
9	27-4301-005	8	1/2" x 1 1/2" GR.5 HDG BOLT		0.13
10	27-5200-005	8	1/2 A36 HDG FLAT WASHER		0.04
11	27-5210-005	20	1/2 HDG LOCK WASHER		0.01
12	27-5222-005	20	1/2 HDG HEX NUT		0.04

THIS DESIGN AND INFORMATION CONTAINED ON THIS PRINT IS THE PROPERTY OF VALLEY FAB CORPORATION. ANY REPRODUCTION, DUPLICATION OR TRANSFER OF THE PROPRIETARY CONTENT IS PROHIBITED WITHOUT WRITTEN PERMISSION.

**STANDARD TOLERANCES:**  
 (UNLESS OTHERWISE NOTED)  
 FRACTIONS ±1/16"  
 DECIMALS ±0.01"  
 ANGLES ±0.5°

**NEWAVE**  
 TOWER COMPONENTS, 503-792-3739  
 10910 PORTLAND RD. BROOKS, OR 97305

TOTAL WT: 122.05 LB  
 QTY:  
 FINISH: HDG  
 JOB #:

TITLE: **LOW PROFILE STIFFENER REINFORCEMENT KIT  
 BOTTOM CLAMP FITS UP TO 5" SQ. TUBE**

SERIES: MONOPOLE MOUNTING SHEET: 1 OF 2

DRAWN BY: KY DATE: 9/3/2020 CHK'D BY: -  
 DRAWING NO. LPSRK-358

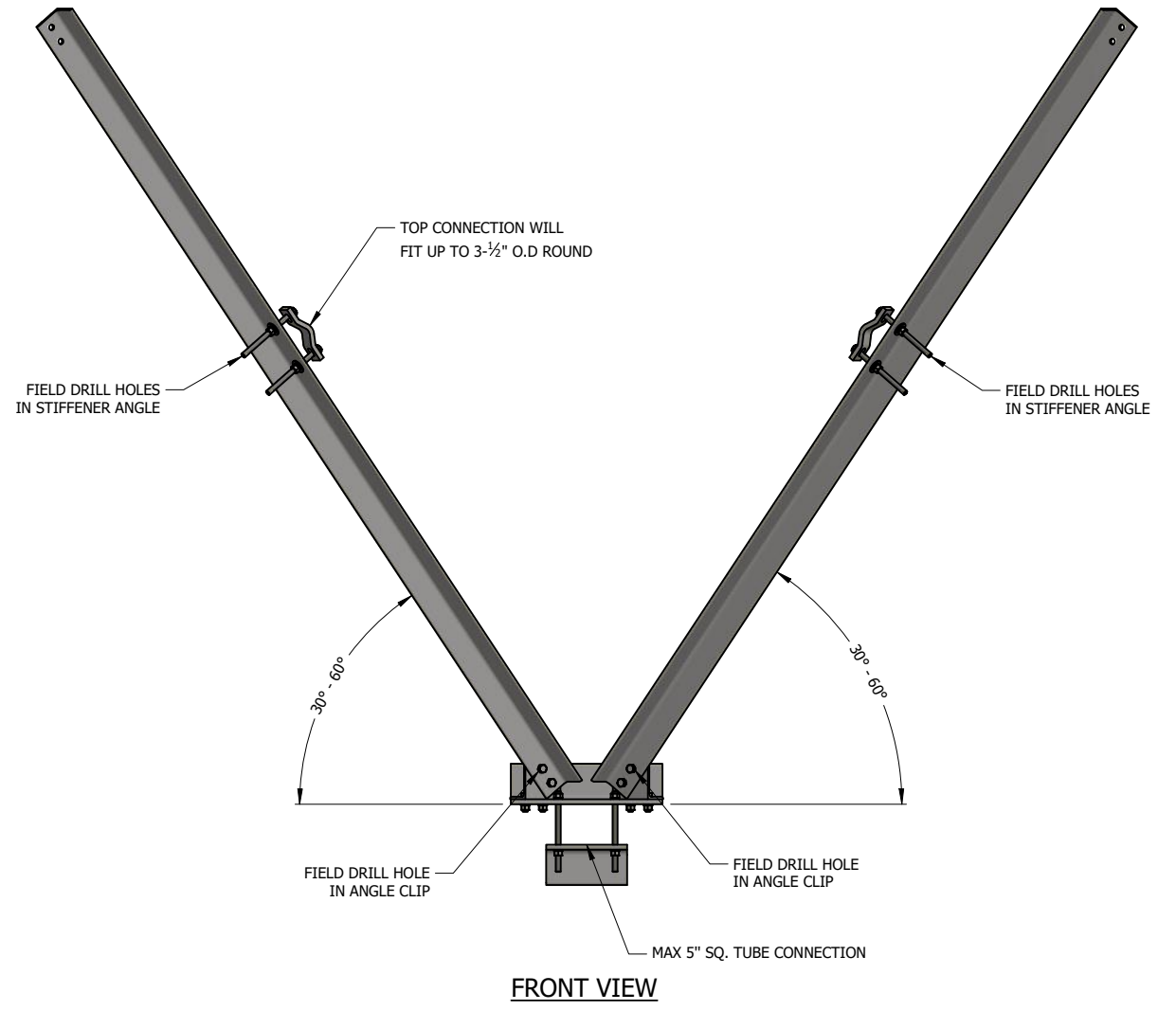
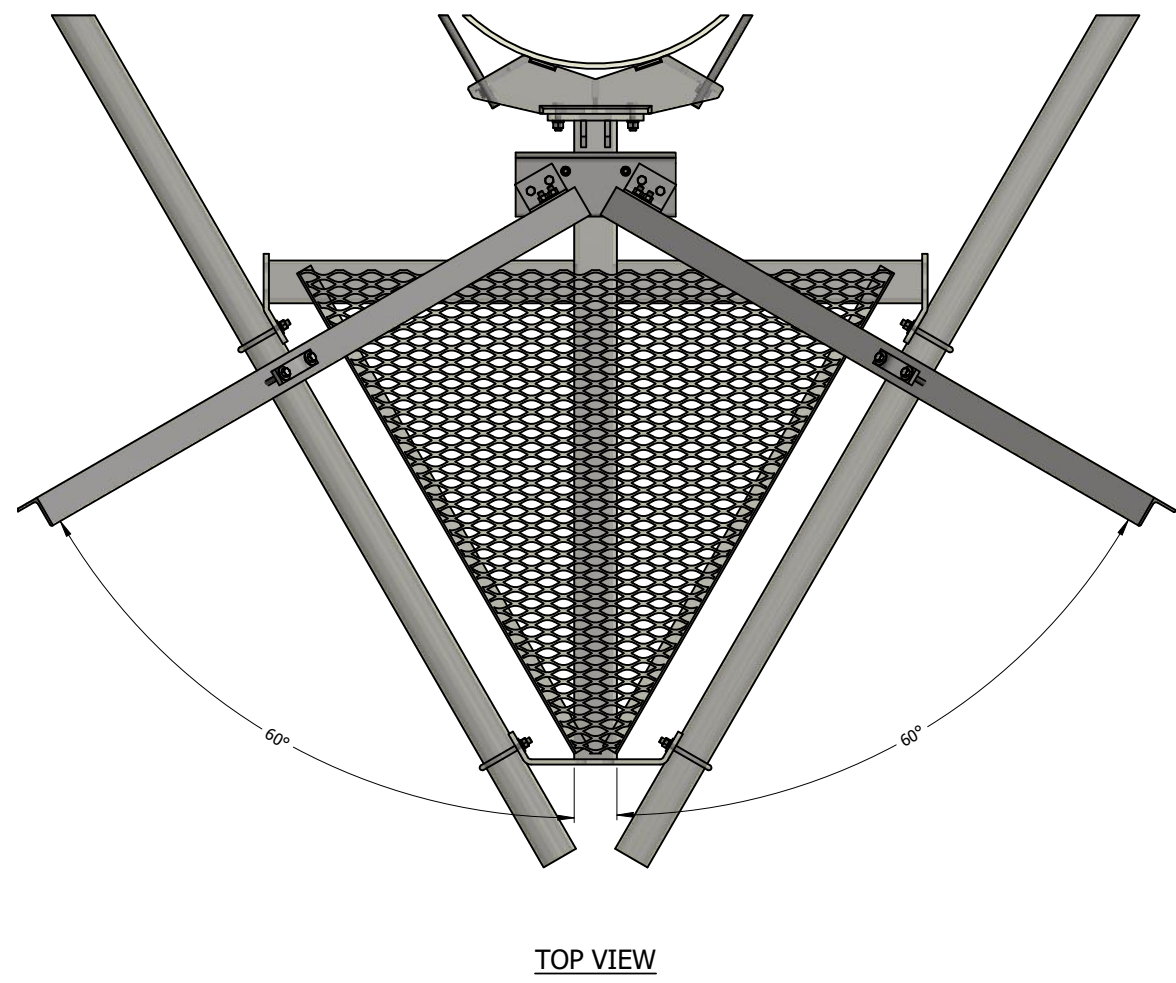

<small>THIS DESIGN AND INFORMATION CONTAINED ON THIS PRINT IS THE PROPERTY OF VALLEY FAB CORPORATION. ANY REPRODUCTION, DUPLICATION OR TRANSFER OF THE PROPRIETARY CONTENT IS PROHIBITED WITHOUT WRITTEN PERMISSION.</small>	
<b>STANDARD TOLERANCES:</b> <small>(UNLESS OTHERWISE NOTED)</small> FRACTIONS ±1/16" DECIMALS ±0.01" ANGLES ±0.5°	 <b>NEWAVE</b> <small>TOWER COMPONENTS, 503-792-3739          10910 PORTLAND RD. BROOKS, OR 97305</small>
<b>TOTAL WT:</b> 122.05 LB <b>QTY:</b> <b>FINISH:</b> HDG <b>JOB #:</b>	<b>TITLE:</b> <b>LOW PROFILE STIFFENER REINFORCEMENT KIT</b> <b>BOTTOM CLAMP FITS UP TO 5" SQ. TUBE</b>

<small>DRAWN BY:</small> KY	<small>DATE:</small> 9/3/2020	<small>CHK'D BY:</small> -
<small>DRAWING NO.</small> LPSRK-358		<small>SHEET:</small> 2 OF 2