

REV	BY	DESCRIPTION	DATE
A	WJ	SEE MODEL I PROPERTIES/COMMENTS	1/8/2020

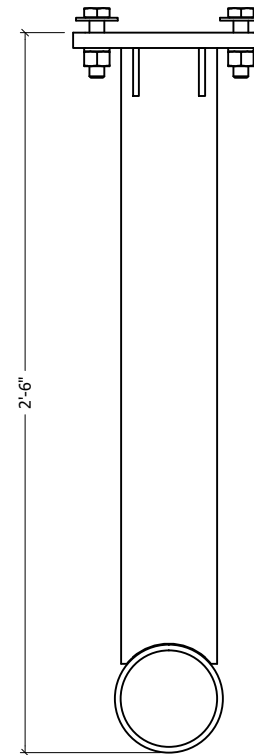
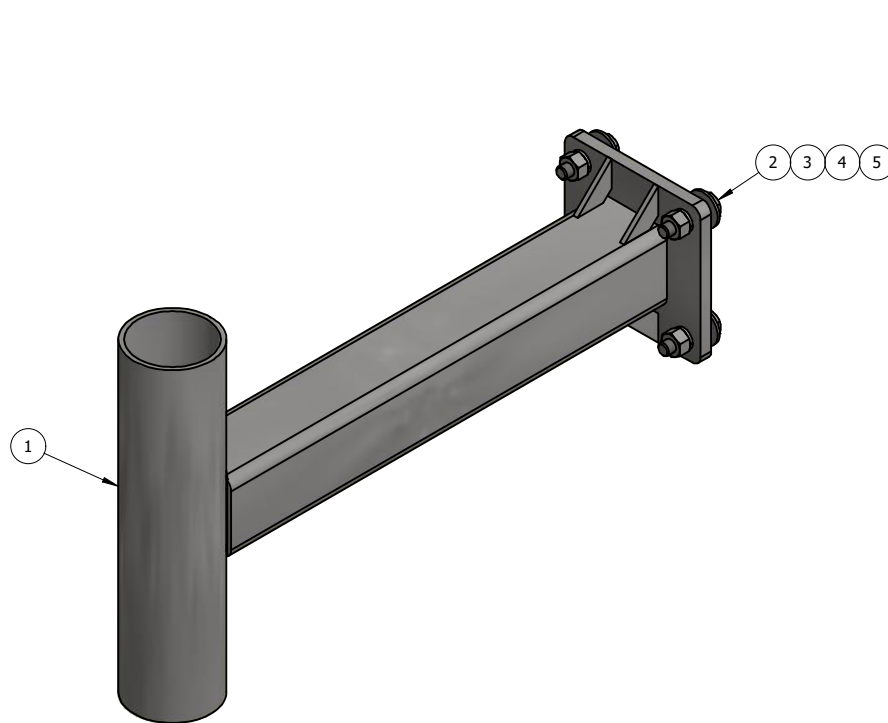

TOP VIEW

ITEM	PART #	QTY	DESCRIPTION	LENGTH	FINISH	UNIT WT
1	M3015-30.01	1	30" STAND OFF WELDMENT		HDG	51.88
2	27-5450-005	4	5/8" x 2 1/2" A325 HDG BOLT			0.32
3	27-5370-005	4	5/8 A36 HDG FLAT WASHER			0.08
4	27-5380-005	4	5/8 HDG LOCK WASHER			0.03
5	27-5390-005	4	5/8" HDG HEAVY HEX NUT			0.13

THIS DESIGN AND INFORMATION CONTAINED ON THIS PRINT IS THE PROPERTY OF VALLEY FAB CORPORATION. ANY REPRODUCTION, DUPLICATION OR TRANSFER OF THE PROPRIETARY CONTENT IS PROHIBITED WITHOUT WRITTEN PERMISSION.

STANDARD TOLERANCES:
(UNLESS OTHERWISE NOTED)
FRACTIONS ±1/16"
DECIMALS ±0.01"
ANGLES ±0.5°

NEWAVE
TOWER COMPONENTS. 503-792-3739
10910 PORTLAND RD. BROOKS, OR 97305

TOTAL WT: 54.1 LB
QTY:
FINISH:
JOB #:

TITLE:	SINGLE SUPPORT ARM 30" STAND OFF		DRAWN BY:	WJ	DATE:	8/6/2019	CHK'D BY:	KY
SERIES:	MONOPOLE MOUNTING		DRAWING NO.		M3015-30			
SHEET:		1 OF 1						