

REV	BY	DESCRIPTION	DATE
A	KY	SEE MODEL I PROPERTIES/COMMENTS	8/12/2024

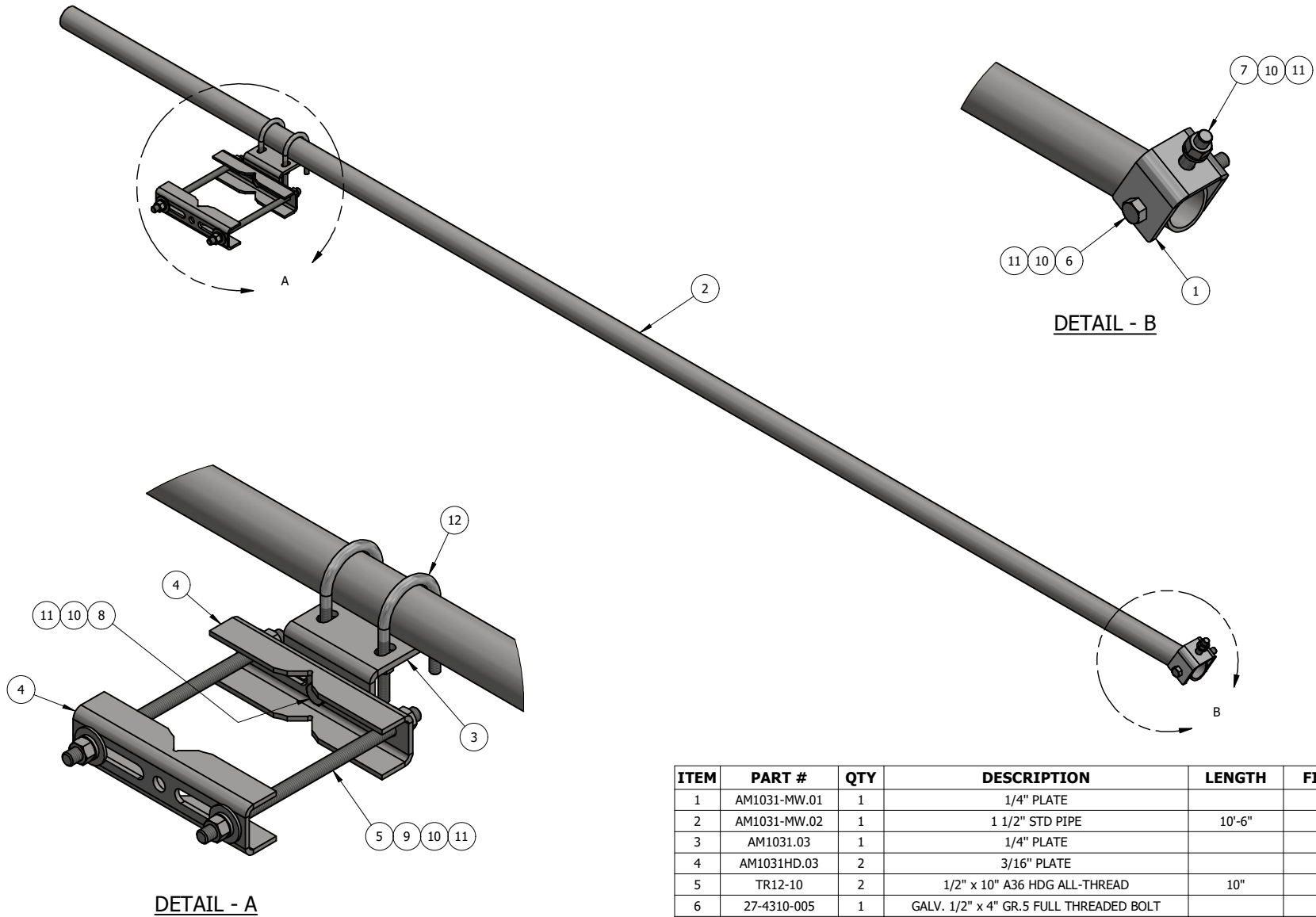

ITEM	PART #	QTY	DESCRIPTION	LENGTH	FINISH	UNIT WT
1	AM1031-MW.01	1	1/4" PLATE		HDG	0.96
2	AM1031-MW.02	1	1 1/2" STD PIPE	10'-6"	HDG	28.55
3	AM1031.03	1	1/4" PLATE		HDG	1.79
4	AM1031HD.03	2	3/16" PLATE		HDG	1.58
5	TR12-10	2	1/2" x 10" A36 HDG ALL-THREAD	10"		0.56
6	27-4310-005	1	GALV. 1/2" x 4" GR.5 FULL THREADED BOLT			0.27
7	27-5261-005	1	GALV. 1/2" x 2" GR.5 FULL THREADED BOLT			0.16
8	27-4300-005	1	1/2" x 1 1/4" GR.5 HDG BOLT			0.12
9	27-5200-005	4	HDG - 1/2" FLAT WASHER, USS			0.04
10	27-5210-005	7	1/2" HDG LOCK WASHER			0.01
11	27-5222-005	7	1/2 HDG HEX NUT			0.04
12	27-6040-005	2	GALV. 3/8" x 2" x 4" U-BOLT ASSEMBLY			0.38

THIS DESIGN AND INFORMATION CONTAINED ON THIS PRINT IS THE PROPERTY OF VALLEY FAB CORPORATION. ANY REPRODUCTION, DUPLICATION OR TRANSFER OF THE PROPRIETARY CONTENT IS PROHIBITED WITHOUT WRITTEN PERMISSION.

**STANDARD TOLERANCES:**  
(UNLESS OTHERWISE NOTED)  
FRACTIONS ±1/16"  
DECIMALS ±0.01"  
ANGLES ±0.5°

**NEWAVE**  
TOWER COMPONENTS. 503-792-3739  
10910 PORTLAND RD. BROOKS, OR 97305

TOTAL WT: 37.45 LB  
QTY:  
FINISH: HDG  
JOB #:

TITLE: STIFF ARM KIT W/ 1-7/8" O.D PIPE @ 10'-6"  
FOR MICROWAVE DISH

DRAWN BY: KY DATE: 4/2/2019 CHK'D BY: KY

SERIES: TOWER ANTENNA MOUNT

SHEET: 1 OF 1

DRAWING NO. AM1031-MW