

PLAN VIEW

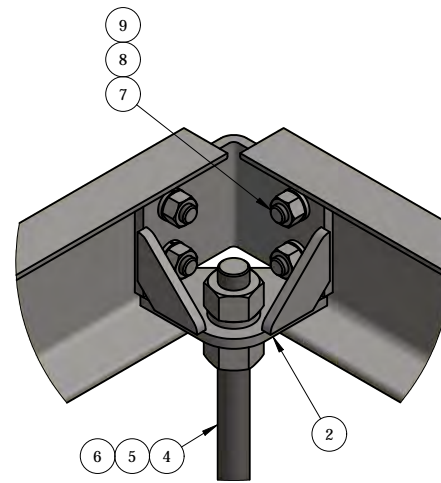

DETAIL - A

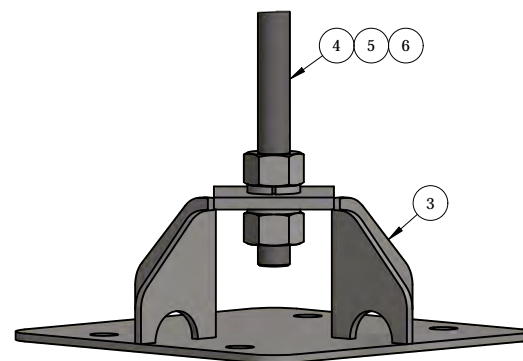

DETAIL - B

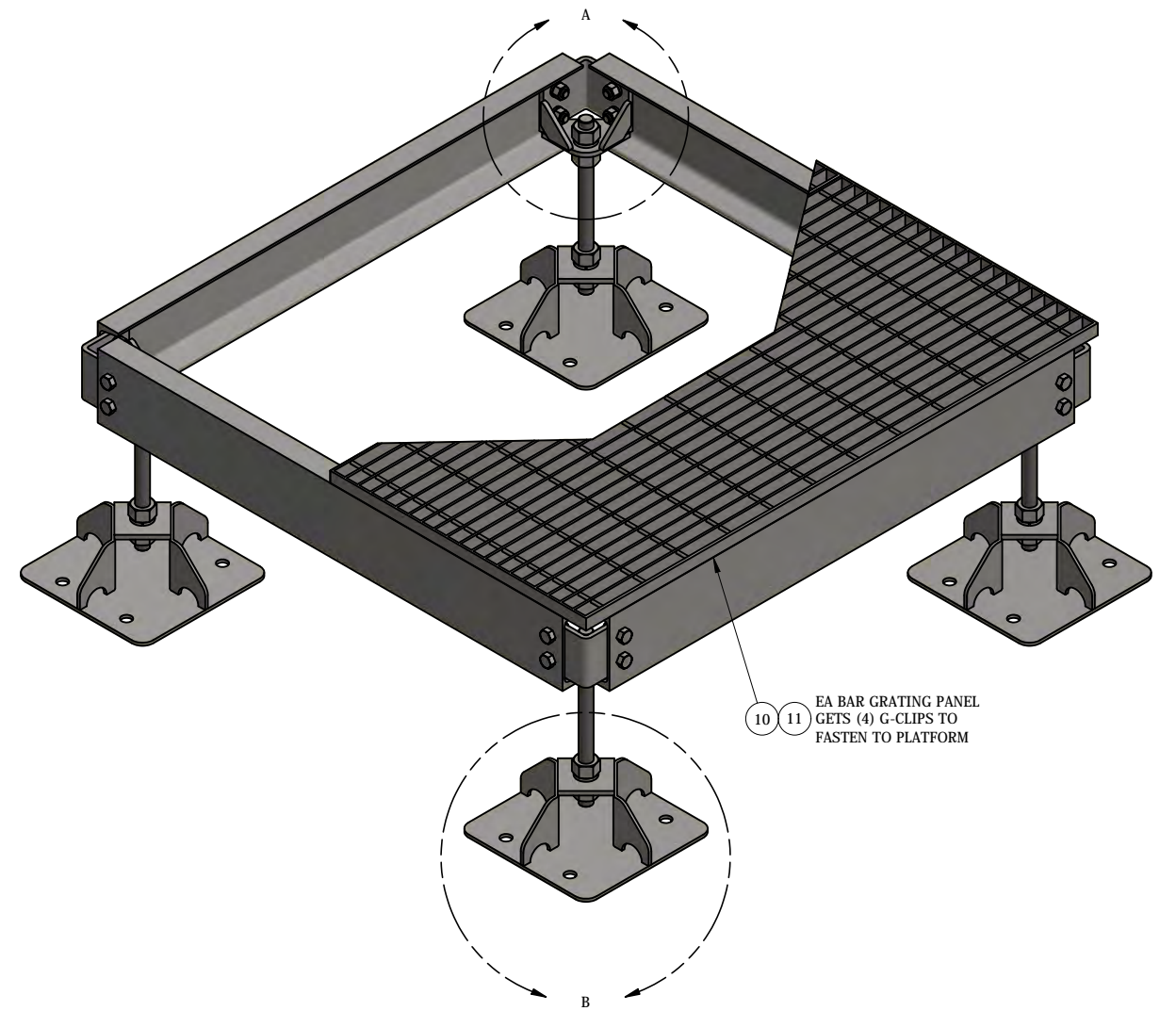

EA BAR GRATING PANEL GETS (4) G-CLIPS TO FASTEN TO PLATFORM

THIS DESIGN AND INFORMATION CONTAINED ON THIS PRINT IS THE PROPERTY OF VALLEY FAB CORPORATION. ANY REPRODUCTION, DUPLICATION OR TRANSFER OF THE PROPRIETARY CONTENT IS PROHIBITED WITHOUT WRITTEN PERMISSION.

**STANDARD TOLERANCES:**  
(UNLESS OTHERWISE NOTED)  
FRACTIONS - 1/16"  
DECIMALS - 0.01"  
ANGLES - 0.5°

**NEWAVE**  
TOWER COMPONENTS, 503-792-3739  
10910 PORTLAND RD. BROOKS, OR 97305

TOTAL WT: 361.65 LB

QTY:

FINISH:

JOB #:

ITEM	PART #	QTY	DESCRIPTION	LENGTH	FINISH	UNIT WT
1	AF4M.01	4	C6x8.2	3'-7 5/8"	HDG	32.51
2	AFCB.01	4	CORNER BRACKET WELDMENT		HDG	5.60
3	AFBP.01	4	BASE PLATE WELDMENT		HDG	15.63
4	27-5740-005	4	1" x 14" A36 HDG ALL-THREAD	1'-2"		3.12
5	27-5704-005	16	1 HDG LOCK WASHER			0.09
6	27-5700-005	16	1 HDG HEAVY HEX NUT			0.47
7	27-4401-005	16	5/8" x 1 1/2" GR.5 HDG BOLT			0.23
8	27-5380-005	16	5/8 HDG LOCK WASHER			0.03
9	27-5391-005	16	5/8" HDG HEX NUT			0.08
10	AF2M.48	2	(19W-4) 1" x 3/16" B.G. @ 2' WIDE	4'	HDG	59.92
11	25-GG1A CLIP	8	GRATING G-CLIP			0.00

TITLE: **4' X 4' MODULAR PLATFORM WITH (4) ADJUSTABLE FEET**  
SERIES: PLATFORMS SHEET: 1 OF 2

DRAWN BY: JG DATE: 1/6/2021 CHK'D BY: CJW  
DRAWING NO. AF44M-4

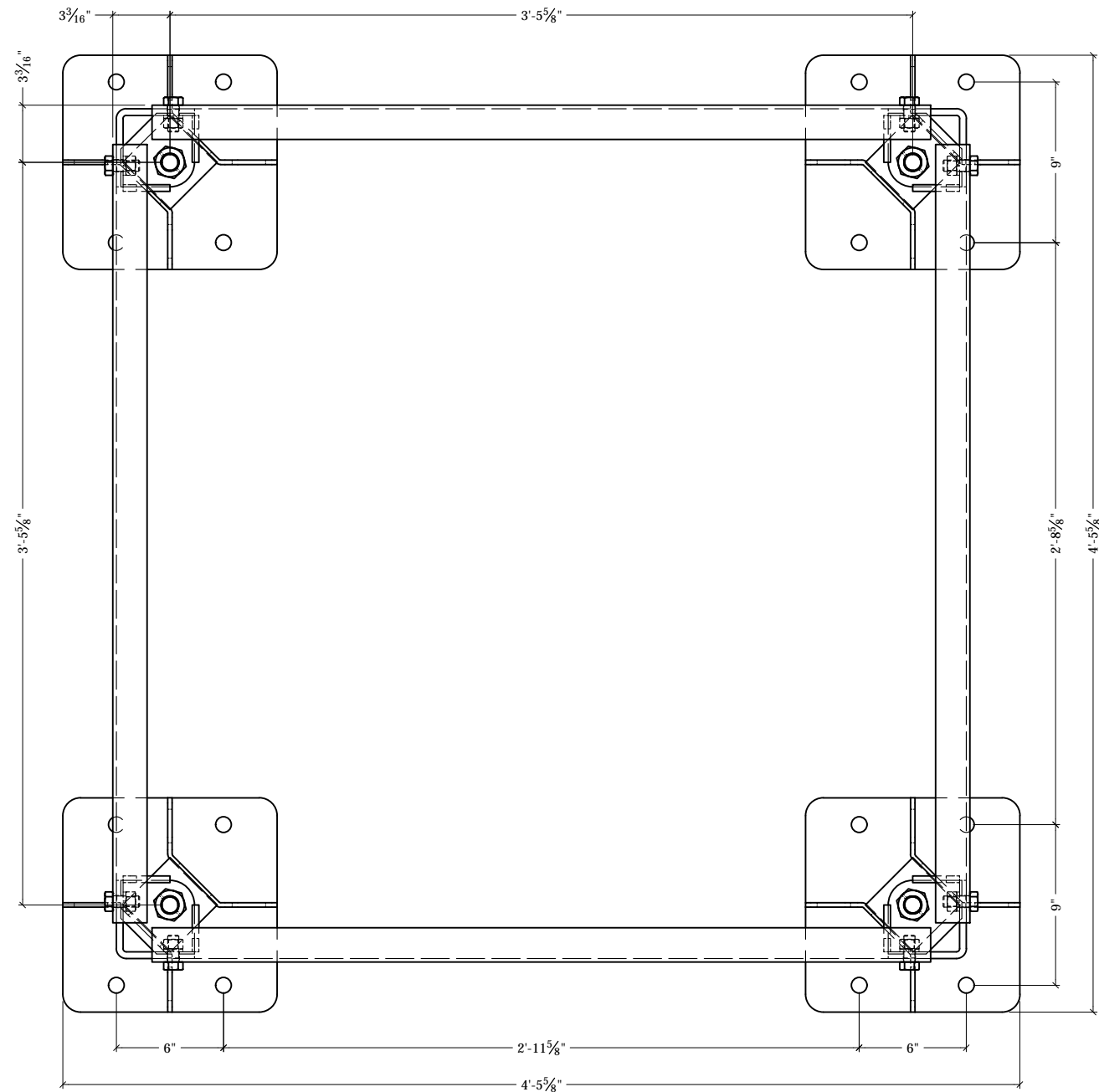

**FOOT PAD LAYOUT**

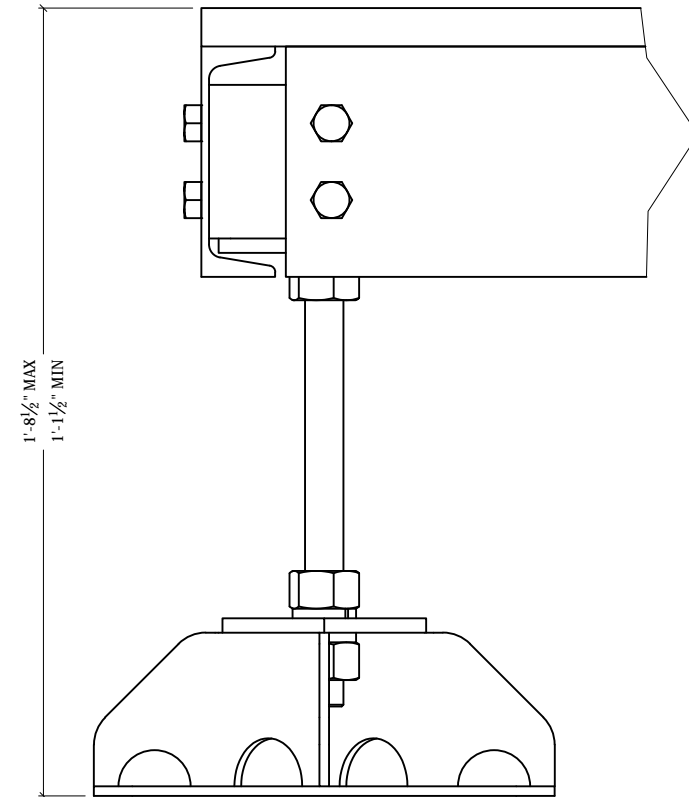

**ELEVATION**

<small>THIS DESIGN AND INFORMATION CONTAINED ON THIS PRINT IS THE PROPERTY OF VALLEY FAB CORPORATION. ANY REPRODUCTION, DUPLICATION OR TRANSFER OF THE PROPRIETARY CONTENT IS PROHIBITED WITHOUT WRITTEN PERMISSION.</small>	
<b>STANDARD TOLERANCES:</b> <small>(UNLESS OTHERWISE NOTED)</small> FRACTIONS - 1/16" DECIMALS - 0.01" ANGLES - 0.5°	 <b>NEWAVE</b> <small>TOWER COMPONENTS, 503-792-3739          10910 PORTLAND RD. BROOKS, OR 97305</small>
<b>TOTAL WT:</b> 361.65 LB <b>QTY:</b> <b>FINISH:</b> <b>JOB #:</b>	<b>4' X 4' MODULAR PLATFORM WITH (4) ADJUSTABLE FEET</b>

<small>TITLE:</small> <b>4' X 4' MODULAR PLATFORM WITH (4) ADJUSTABLE FEET</b>	<small>DRAWN BY:</small> JG <small>DATE:</small> 1/6/2021 <small>CHK'D BY:</small> CJW
<small>SERIES:</small> PLATFORMS <small>SHEET:</small> 2 OF 2	<small>DRAWING NO.:</small> AF44M-4