

PLAN VIEW

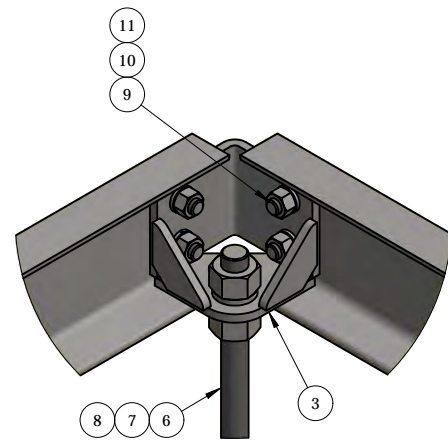

DETAIL - A

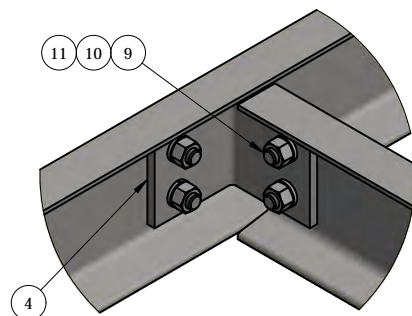

DETAIL - B

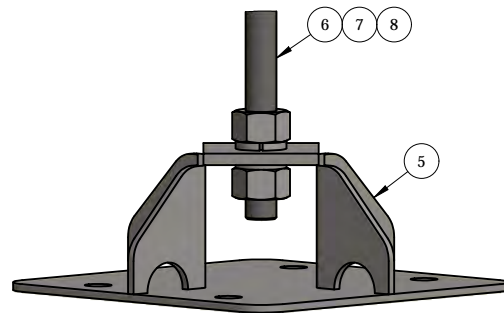

DETAIL - C

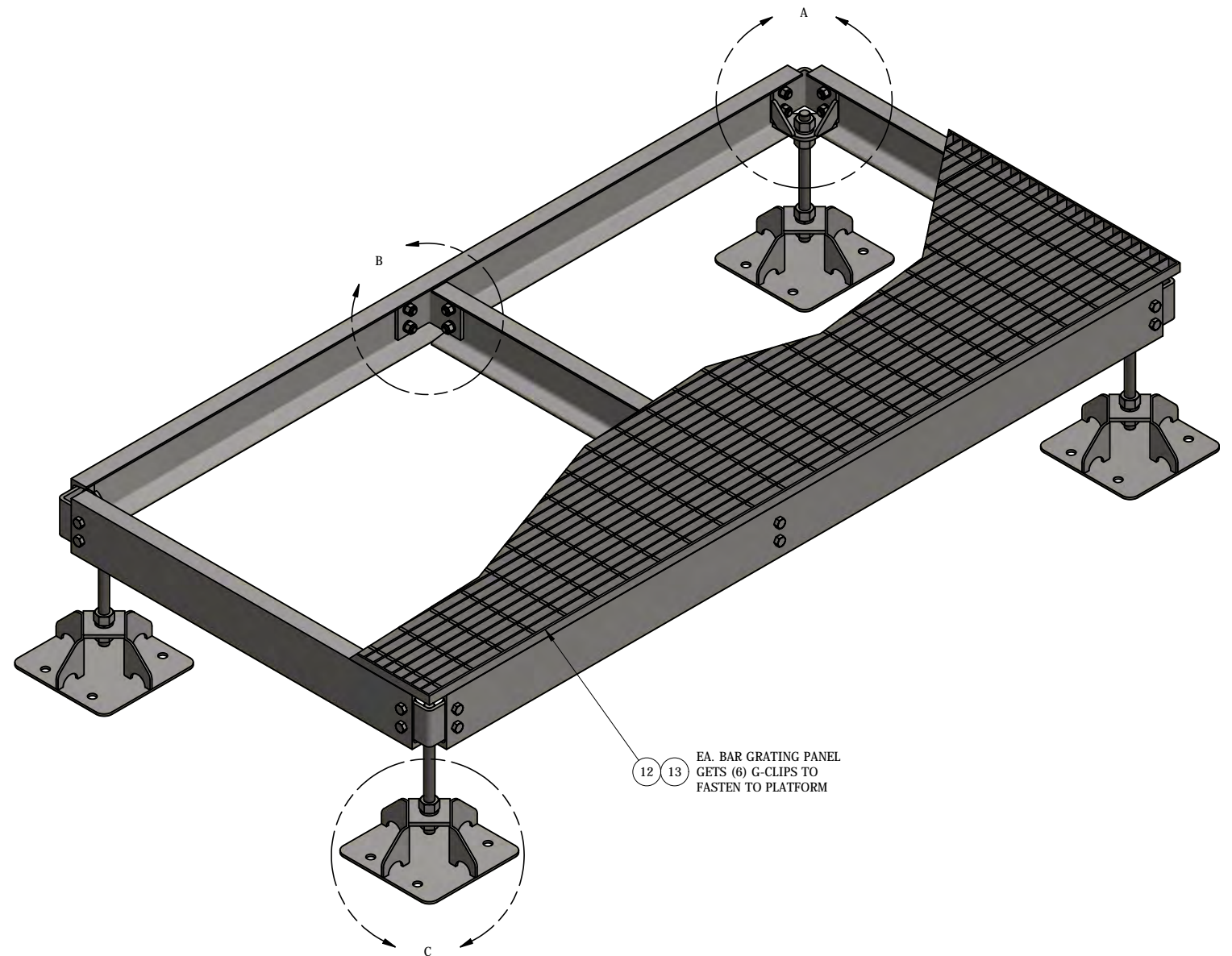

EA. BAR GRATING PANEL GETS (6) G-CLIPS TO FASTEN TO PLATFORM

ITEM	PART #	QTY	DESCRIPTION	LENGTH	FINISH	UNIT WT
1	AF4M.01	3	C6x8.2	3'-7 5/8"	HDG	32.51
2	AF8M.01	2	C6x8.2	7'-7 5/8"	HDG	68.36
3	AFCB.01	4	CORNER BRACKET WELDMENT		HDG	5.60
4	AFCB.02	2	3/8" PLATE		SEE W/O	3.34
5	AFBP.01	4	BASE PLATE WELDMENT		HDG	15.63
6	27-5740-005	4	1" x 14" A36 HDG ALL-THREAD	1'-2"		3.12
7	27-5704-005	16	1 HDG LOCK WASHER			0.09
8	27-5700-005	16	1 HDG HEAVY HEX NUT			0.47
9	27-4401-005	24	5/8" x 1 1/2" GR.5 HDG BOLT			0.23
10	27-5380-005	24	5/8 HDG LOCK WASHER			0.03
11	27-5391-005	24	5/8" HDG HEX NUT			0.08
12	AF2M.96	2	(19W-4) 1" x 3/16" B.G. @ 2" WIDE	8'	HDG	117.71
13	25-GG1A CLIP	12	GRATING G-CLIP			0.00

THIS DESIGN AND INFORMATION CONTAINED ON THIS PRINT IS THE PROPERTY OF VALLEY FAB CORPORATION. ANY REPRODUCTION, DUPLICATION OR TRANSFER OF THE PROPRIETARY CONTENT IS PROHIBITED WITHOUT WRITTEN PERMISSION.

STANDARD TOLERANCES:
(UNLESS OTHERWISE NOTED)
FRACTIONS - 1/16"
DECIMALS - 0.01"
ANGLES - 0.5°

NEWAVE
TOWER COMPONENTS, 503-792-3739
10910 PORTLAND RD. BROOKS, OR 97305

TOTAL WT: 590.8 LB
QTY:
FINISH:
JOB #:

TITLE:	4' x 8' MODULAR PLATFORM WITH (4) ADJUSTABLE FEET	DRAWN BY: JG	DATE: 1/6/2021	CHK'D BY: CJW
SERIES: PLATFORMS	SHEET: 1 OF 2	DRAWING NO. AF48M-4		

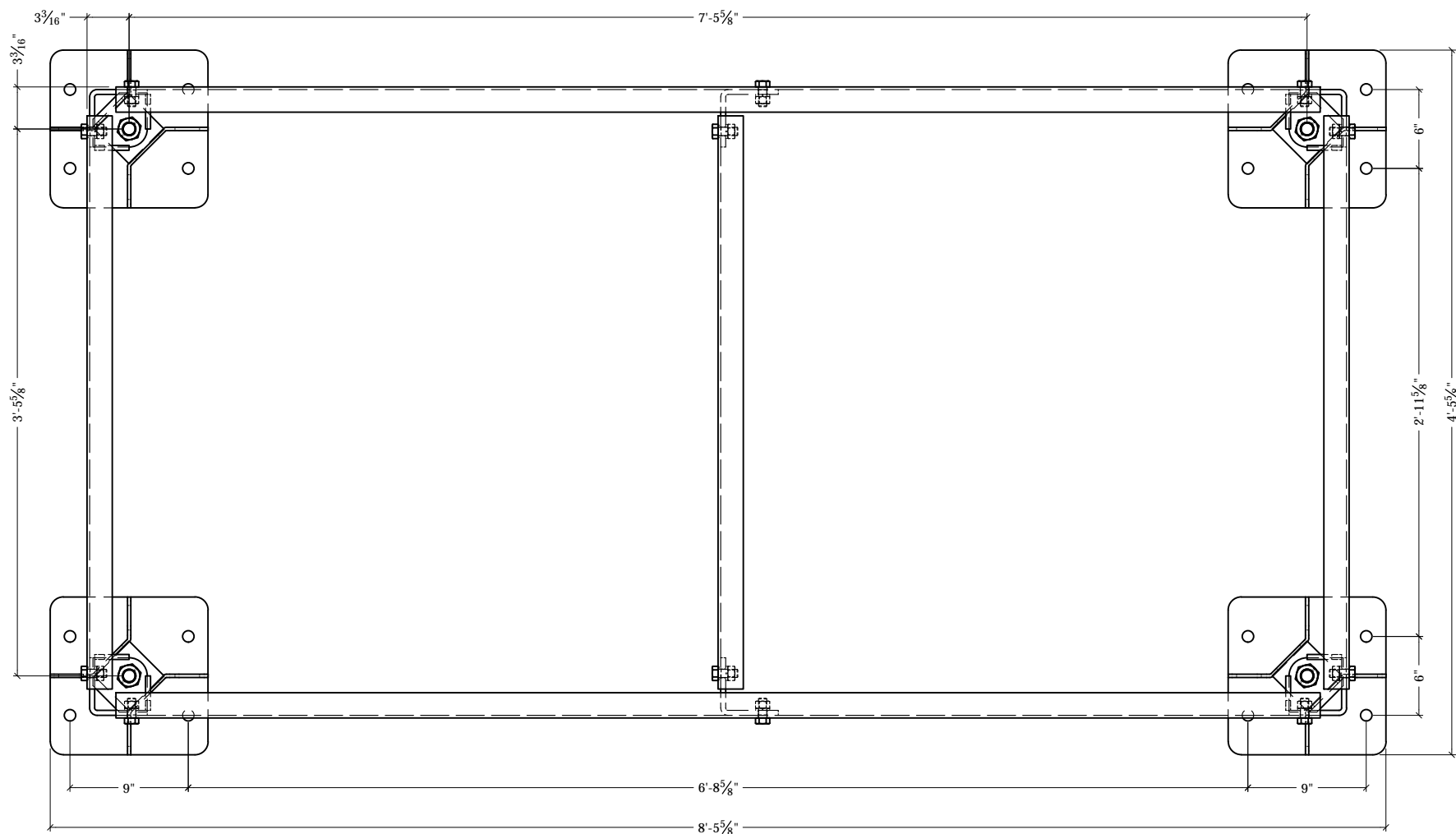

FOOT PAD LAYOUT

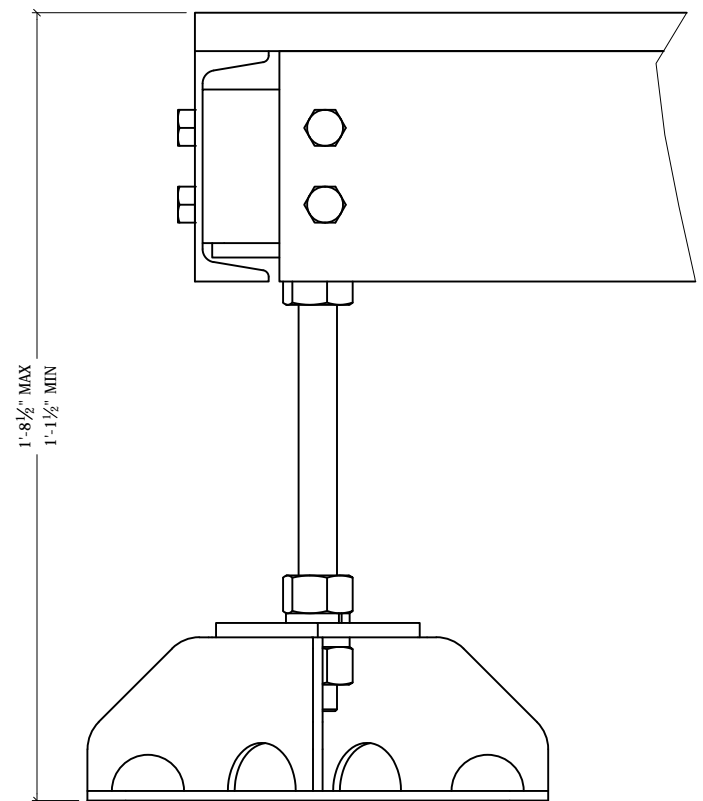

ELEVATION

THIS DESIGN AND INFORMATION CONTAINED ON THIS PRINT IS THE PROPERTY OF VALLEY FAB CORPORATION. ANY REPRODUCTION, DUPLICATION OR TRANSFER OF THE PROPRIETARY CONTENT IS PROHIBITED WITHOUT WRITTEN PERMISSION.	
STANDARD TOLERANCES: (UNLESS OTHERWISE NOTED) FRACTIONS - 1/16" DECIMALS - 0.01" ANGLES - 0.5°	 NEWAVE TOWER COMPONENTS, 503-792-3739 10910 PORTLAND RD. BROOKS, OR 97305
TOTAL WT: 590.8 LB	TITLE:
QTY:	4' x 8' MODULAR PLATFORM
FINISH:	WITH (4) ADJUSTABLE FEET
JOB #:	SERIES: PLATFORMS

DRAWN BY: JG	DATE: 1/6/2021	CHK'D BY: CJW
DRAWING NO. AF48M-4		SHEET: 2 OF 2