

PLAN VIEW

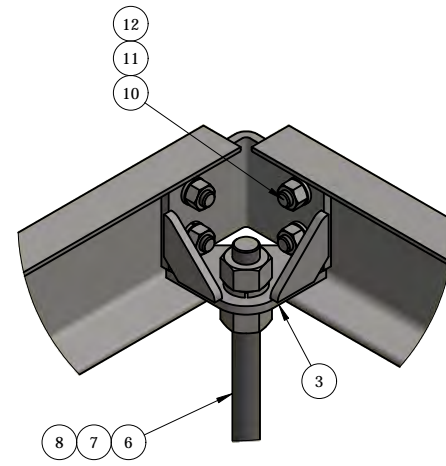

DETAIL - A

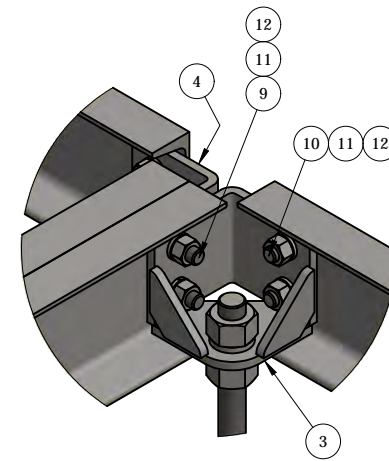

DETAIL - B

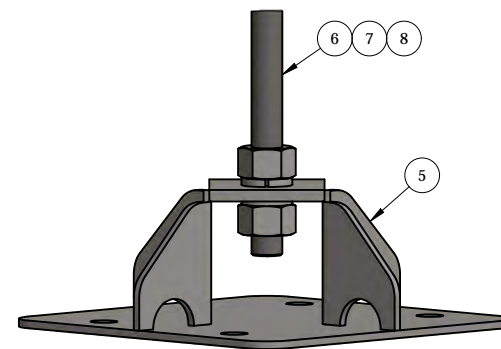

DETAIL - C

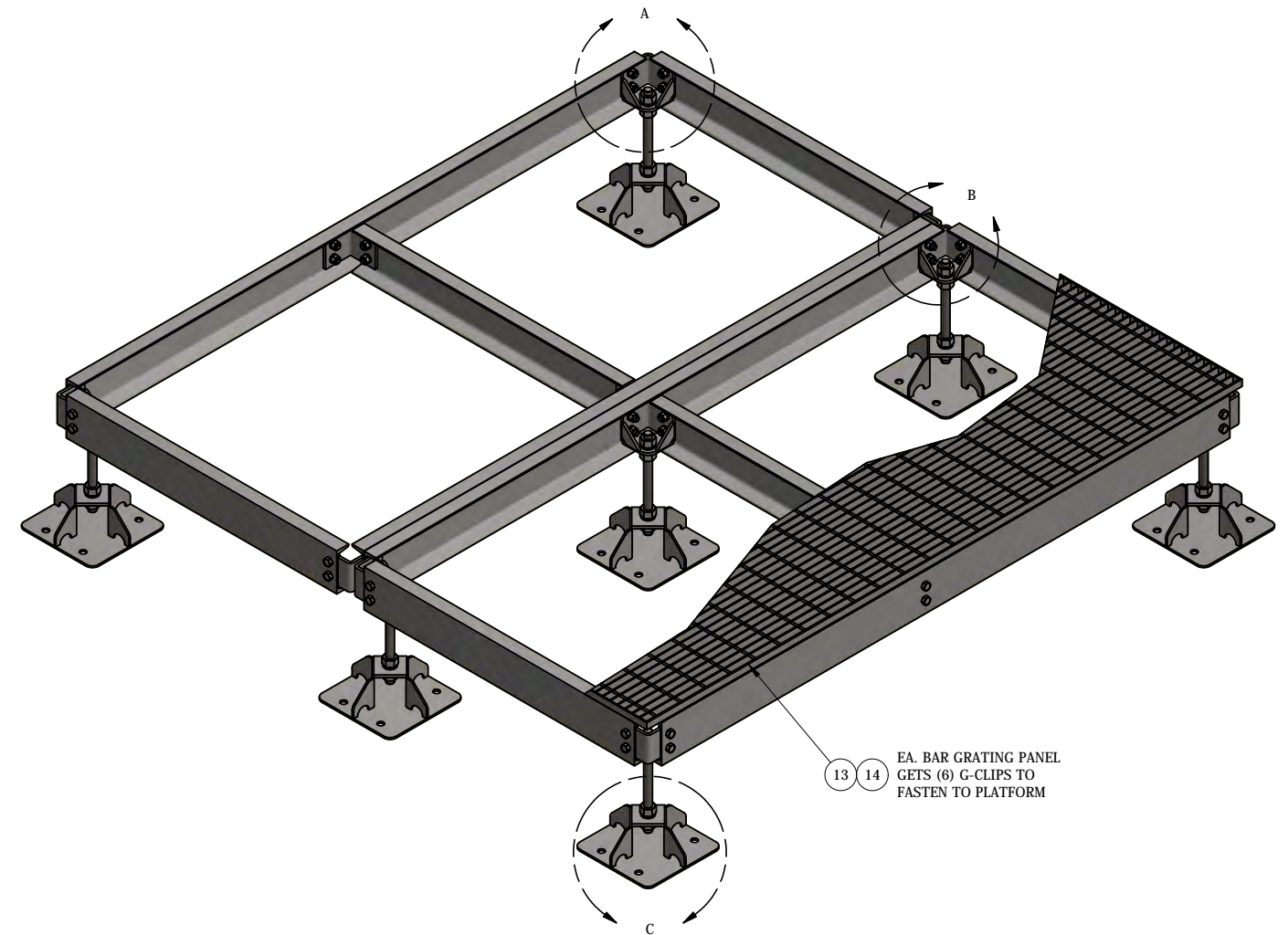

ITEM	PART #	QTY	DESCRIPTION	LENGTH	FINISH	UNIT WT
1	AF4M.01	6	C6x8.2	3'-7 5/8"	HDG	32.51
2	AF8M.01	4	C6x8.2	7'-7 5/8"	HDG	68.36
3	AFCB.01	7	CORNER BRACKET WELDMENT		HDG	5.60
4	AFCB.02	5	3/8" PLATE		SEE W/O	3.34
5	AFBP.01	7	BASE PLATE WELDMENT		HDG	15.63
6	27-5740-005	7	1" x 14" A36 HDG ALL-THREAD	1'-2"		3.12
7	27-5704-005	28	1 HDG LOCK WASHER			0.09
8	27-5700-005	28	1 HDG HEAVY HEX NUT			0.47
9	27-4404-005	6	5/8" x 2 1/4" GR.5 HDG BOLT			0.29
10	27-4401-005	36	5/8" x 1 1/2" GR.5 HDG BOLT			0.23
11	27-5380-005	42	5/8 HDG LOCK WASHER			0.03
12	27-5391-005	42	5/8" HDG HEX NUT			0.08
13	AF2M.96	4	(19W-4) 1" x 3/16" B.G. @ 2' WIDE	8'	HDG	117.71
14	25-GG1A CLIP	24	GRATING G-CLIP			0.00

THIS DESIGN AND INFORMATION CONTAINED ON THIS PRINT IS THE PROPERTY OF VALLEY FAB CORPORATION. ANY REPRODUCTION, DUPLICATION OR TRANSFER OF THE PROPRIETARY CONTENT IS PROHIBITED WITHOUT WRITTEN PERMISSION.

STANDARD TOLERANCES:
(UNLESS OTHERWISE NOTED)
FRACTIONS - 1/16"
DECIMALS - 0.01"
ANGLES - 0.5°

NEWAVE
TOWER COMPONENTS, 503-792-3739
10910 PORTLAND RD. BROOKS, OR 97305

TOTAL WT: 1156.7 LB
QTY:
FINISH:
JOB #:

TITLE: 8' X 8' MODULAR PLATFORM WITH (7) ADJUSTABLE FEET

SERIES: PLATFORMS SHEET: 1 OF 2

DRAWN BY: JG DATE: 1/7/2020 CHK'D BY: CJW

DRAWING NO. AF88M-7

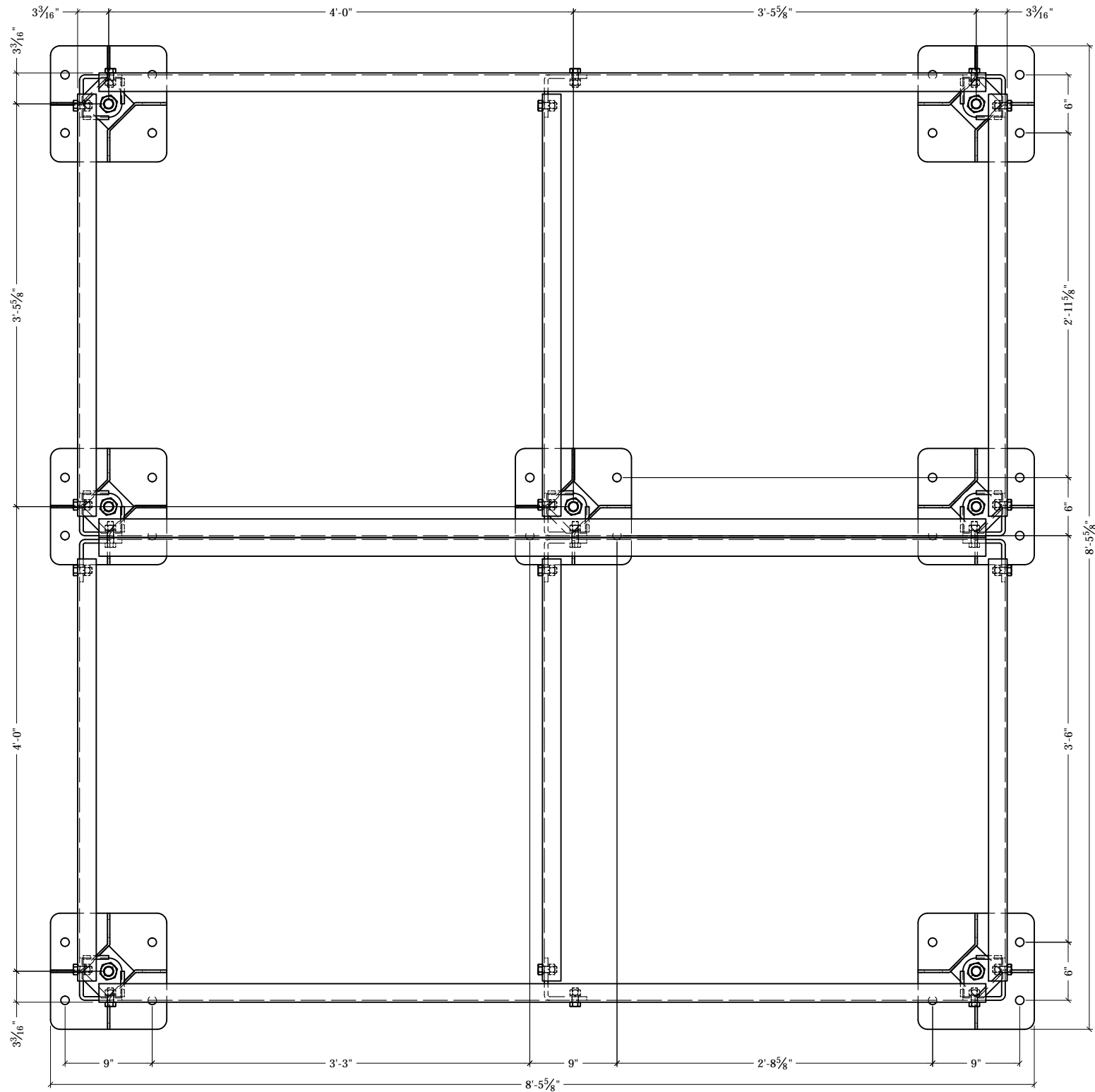

FOOT PAD LAYOUT

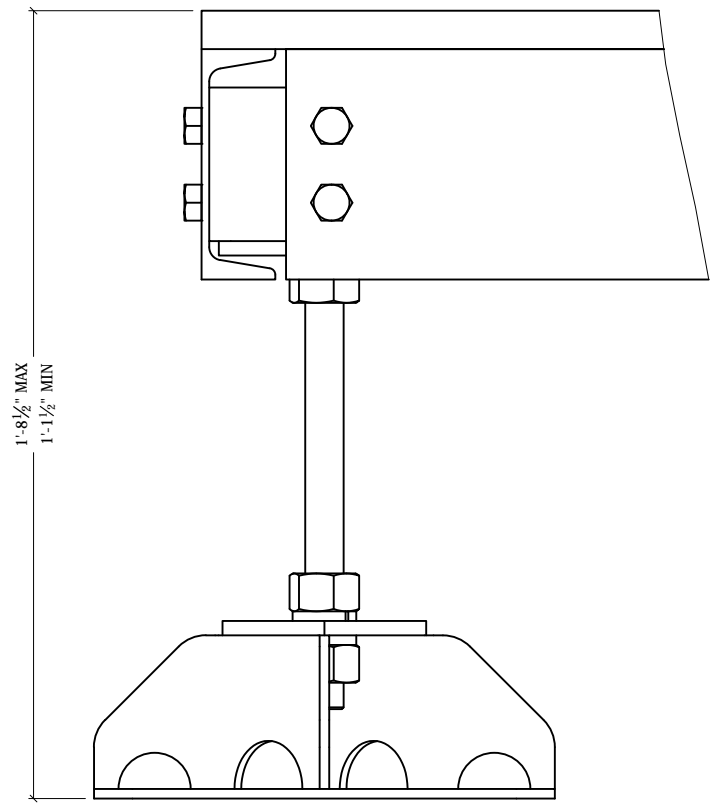

ELEVATION

<p>THIS DESIGN AND INFORMATION CONTAINED ON THIS PRINT IS THE PROPERTY OF VALLEY FAB CORPORATION. ANY REPRODUCTION, DUPLICATION OR TRANSFER OF THE PROPRIETARY CONTENT IS PROHIBITED WITHOUT WRITTEN PERMISSION.</p>	
<p>STANDARD TOLERANCES: (UNLESS OTHERWISE NOTED) FRACTIONS - 1/16" DECIMALS - 0.01" ANGLES - 0.5°</p>	<p>NEWAVE TOWER COMPONENTS, 503-792-3739 10910 PORTLAND RD. BROOKS, OR 97305</p>
<p>TOTAL WT: 1156.7 LB</p>	<p>QTY:</p>
<p>FINISH:</p>	<p>JOB #:</p>

TITLE:	8' X 8' MODULAR PLATFORM WITH (7) ADJUSTABLE FEET
SERIES:	PLATFORMS
SHEET:	2 OF 2

DRAWN BY:	DATE:	CHK'D BY:
JG	1/7/2020	CJW
DRAWING NO.		AF88M-7