

FRONT VIEW

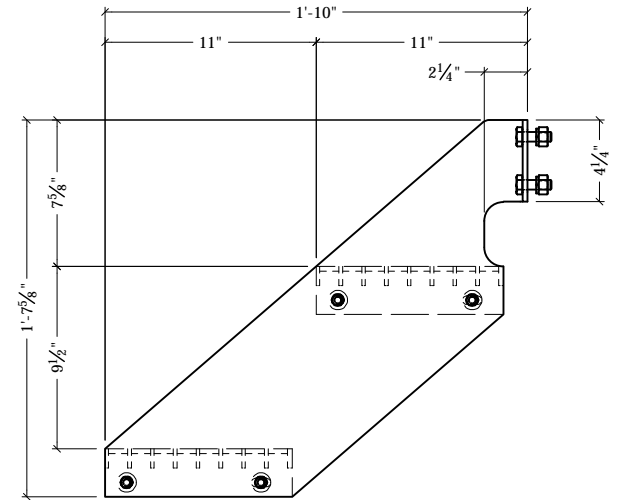

SIDE VIEW
 MAX RISE NOT
 TO EXCEED 9 1/2"
 WHEN MOUNTED

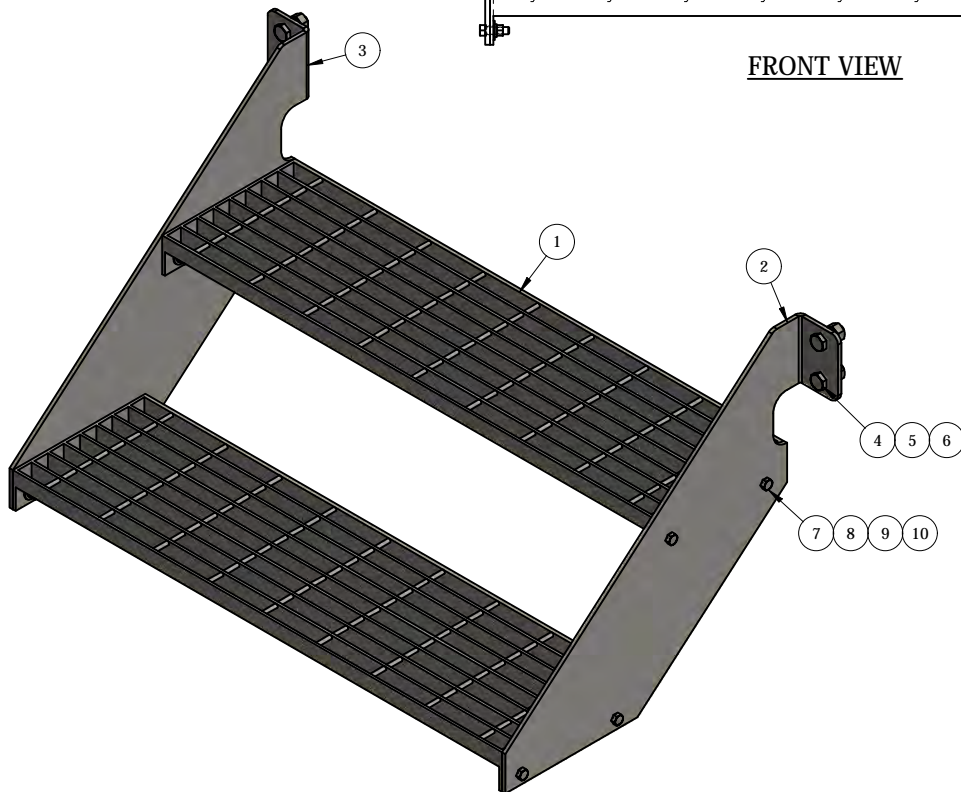

ITEM	PART #	QTY	DESCRIPTION	LENGTH	FINISH	UNIT WT
1	AFMS-36.01	2	(19W-4) 1" x 3/16" B.G. @ 9 3/4" WIDE	3'	HDG	21.22
2	AFMS2.01	1	1/4" PLATE		HDG	14.01
3	AFMS2.02	1	1/4" PLATE		HDG	14.01
4	27-5240-005	4	1/2" x 1 1/2" A325 HDG BOLT			0.14
5	27-5210-005	4	1/2" HDG LOCK WASHER			0.01
6	27-5220-005	4	1/2" HDG HEAVY HEX NUT			0.07
7	27-4201-005	8	3/8" x 1 1/4" GR.5 HDG BOLT			0.06
8	27-5010-005	8	3/8" A36 HDG FLAT WASHER			0.01
9	27-5020-005	8	3/8" HDG LOCK WASHER			0.01
10	27-5030-005	8	3/8" HDG HEX NUT			0.02

THIS DESIGN AND INFORMATION CONTAINED ON THIS PRINT IS THE PROPERTY OF VALLEY FAB CORPORATION. ANY REPRODUCTION, DUPLICATION OR TRANSFER OF THE PROPRIETARY CONTENT IS PROHIBITED WITHOUT WRITTEN PERMISSION.

STANDARD TOLERANCES:

(UNLESS OTHERWISE NOTED)
 FRACTIONS - 1/16"
 DECIMALS - 0.01"
 ANGLES - 0.5°



TOTAL WT: 72.15 LB

QTY:

FINISH:

JOB #:

TITLE:

36" WIDE DOUBLE STEP FOR ADJUSTABLE FOOT
 MODULAR PLATFORM, FITS C6x8.2 & W6x9

SERIES: PLATFORMS

SHEET: 1 OF 1

DRAWN BY:

JG

DATE:

9/24/2019

CHK'D BY:

CJW

DRAWING NO.

AFMS2-36