

SIDE VIEW

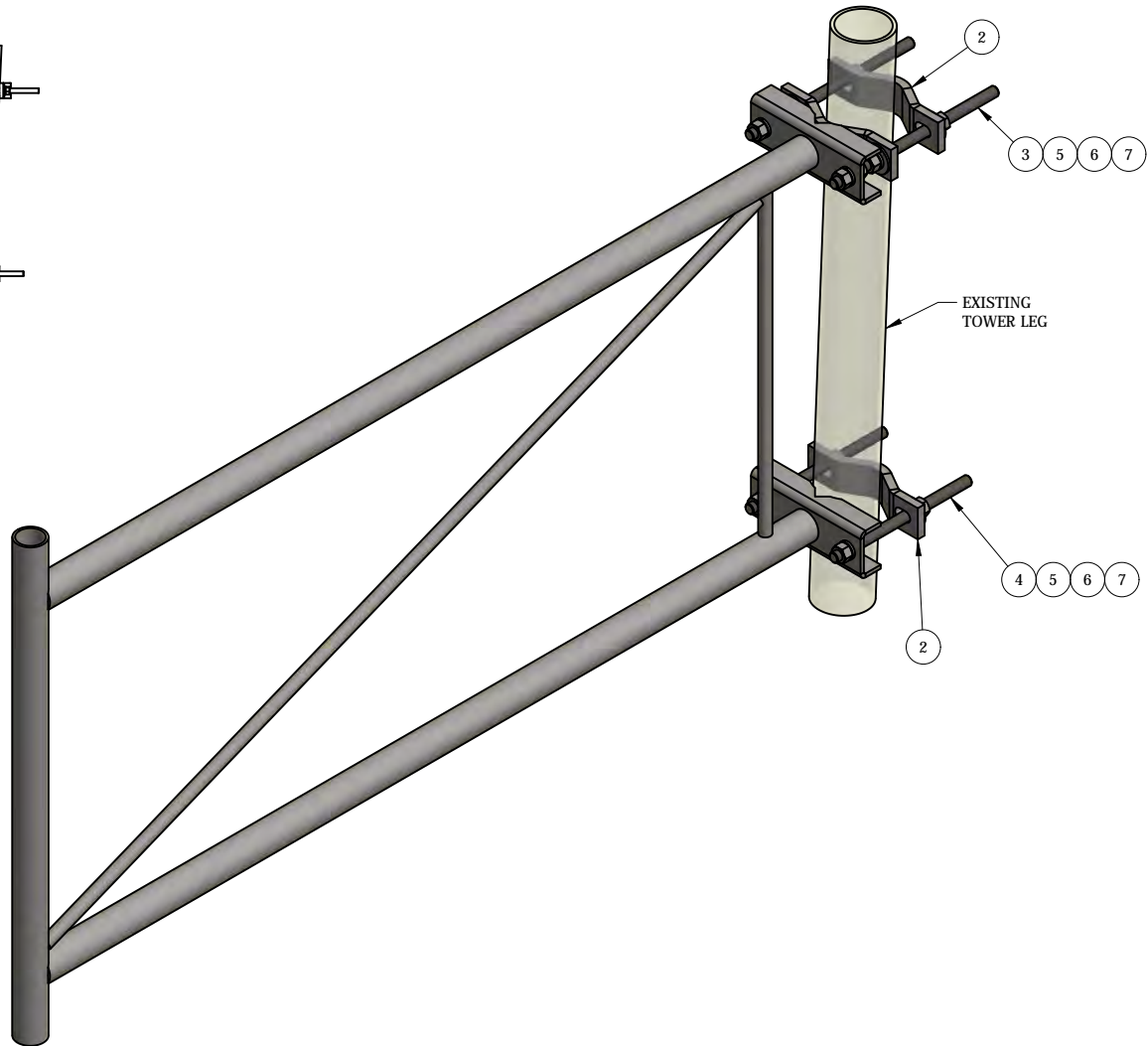

ITEM	PART #	QTY	DESCRIPTION	FINISH	UNIT WT
1	AM1012-60.01	1	60" STAND OFF WELDMENT	HDG	48.54
2	AMCS-5.01	3	1/2" PLATE	SEE W/O	2.25
3	TR58-12	2	5/8" x 12" A36 HDG ALL-THREAD		1.04
4	TR58-10	2	5/8" x 10" A36 HDG ALL-THREAD		0.87
5	27-5370-005	6	5/8 A36 HDG FLAT WASHER		0.08
6	27-5380-005	12	5/8 HDG LOCK WASHER		0.03
7	27-5391-005	12	5/8" HDG HEX NUT		0.08

THIS DESIGN AND INFORMATION CONTAINED ON THIS PRINT IS THE PROPERTY OF VALLEY FAB CORPORATION. ANY REPRODUCTION, DUPLICATION OR TRANSFER OF THE PROPRIETARY CONTENT IS PROHIBITED WITHOUT WRITTEN PERMISSION.

STANDARD TOLERANCES:

(UNLESS OTHERWISE NOTED)
 FRACTIONS - 1/16"
 DECIMALS - 0.01"
 ANGLES - 0.5°

NEW WAVE
 TOWER COMPONENTS. 503-792-3739
 10910 PORTLAND RD. BROOKS, OR 97305

TOTAL WT: 60.9 LB

QTY:

FINISH:

JOB #:

TITLE:
**60" STAND OFF MOUNT FOR TAPERED MOUNTING
 32" VERTICAL FACE PIPE**

SERIES: TOWER ANTENNA MOUNT

SHEET: 1 OF 1

DRAWN BY: **KY** DATE: **10/18/2019** CHK'D BY: **JG**

DRAWING NO.
AM1012-60T