

ITEM	PART #	DESCRIPTION	QTY	UNIT WT
1	AM1022-24.01	ADJUSTABLE TAPERED 24" STAND OFF PIPE WELDMENT	1	103.70
2	AM1026-45.04	3/8" BENT ADJUSTABLE SLIDER MOUNT PLATE	1	10.12
3	AM1026-45.05	1/4" BENT ANGLE ARM PLATE	2	6.15
4	AM1026-45.06	BASE ANTENNA MOUNT WELDMENT	1	12.22
5	AM1029-U.01	UNIVERSALTOWER LEG "L" BENT MOUNT PLATE	2	4.82
6	AM1029-U.02	UNIVERSAL ANGLE MOUNT PLATE (FOR ANGLE LEG ONLY)	2	1.98
7	AMCS-8.01	HALF CLAMP FOR 3-1/2" TO 8-5/8" ROUND MEMBER	4	3.39
8	27-5578-005	GALV. 3/4" B7 ALL THREAD @ 18" LONG	1	2.25
9	27-5481-005	GALV. 3/4" FLAT WASHER	2	0.09
10	27-5490-005	GALV. 3/4" LOCK WASHER	2	0.05
11	27-5501-005	GALV. 3/4" HEX NUT REGULAR	2	0.14
12	TR58-12	GALV. 5/8" x 12" ALL-THREAD	8	1.04
13	TR58-8	GALV. 5/8" x 8" ALL-THREAD	1	0.70
14	27-4404-005	GALV. 5/8" x 2-1/4" GR.5 BOLT	4	0.29
15	27-4403-005	GALV. 5/8" x 2" GR.5 BOLT	4	0.27
16	27-5370-005	GALV. 5/8" FLAT WASHER	16	0.07
17	27-5380-005	GALV. 5/8" LOCK WASHER	28	0.03
18	27-5391-005	GALV. 5/8" HEX NUT	28	0.08

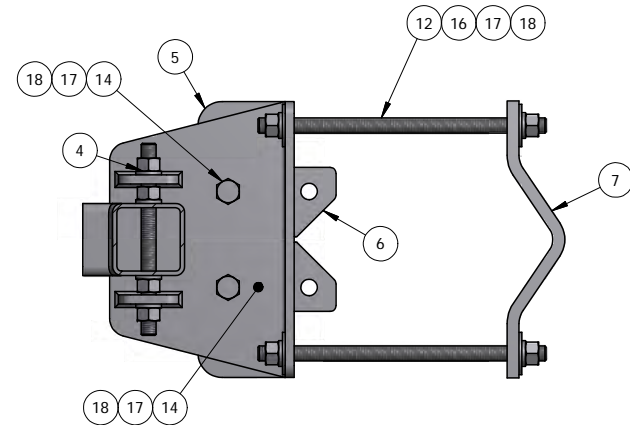

DETAIL A

QTY:
CHK:

STANDARD TOLERANCES:
(UNLESS OTHERWISE NOTED)
FRACTIONS ±1/16"
DECIMALS ±.005"
ANGLES ±.5°

THIS DESIGN AND INFORMATION CONTAINED ON THIS PRINT IS THE PROPERTY OF NEWAVE TOWER COMPONENTS LLC. ANY REPRODUCTION, DUPLICATION OR TRANSFER OF THE PROPRIETARY CONTENT IS PROHIBITED WITHOUT WRITTEN PERMISSION.

NEWAVE
Tower Components
503-792-3739
10910 PORTLAND RD. BROOKS, OR 97305

MATERIAL: AS SHOWN
HOLES: AS SHOWN
FINISH: HDG
DRAWN BY: KY
CHECKED BY:
DATE: 1/2/2014

TITLE: ADJUSTABLE TAPERED 24" STAND OFF PIPE MOUNT
SERIES: TOWER ANTENNA MOUNTING
PART WT (BARE): 192.9 LB
DRAWING NO. AM1022-24
SHEET: 1 OF 1