

DETAIL - A

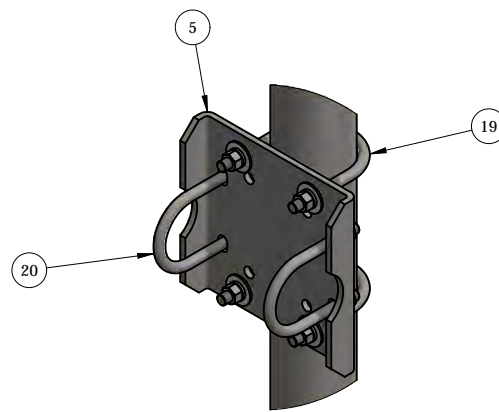

DETAIL - B

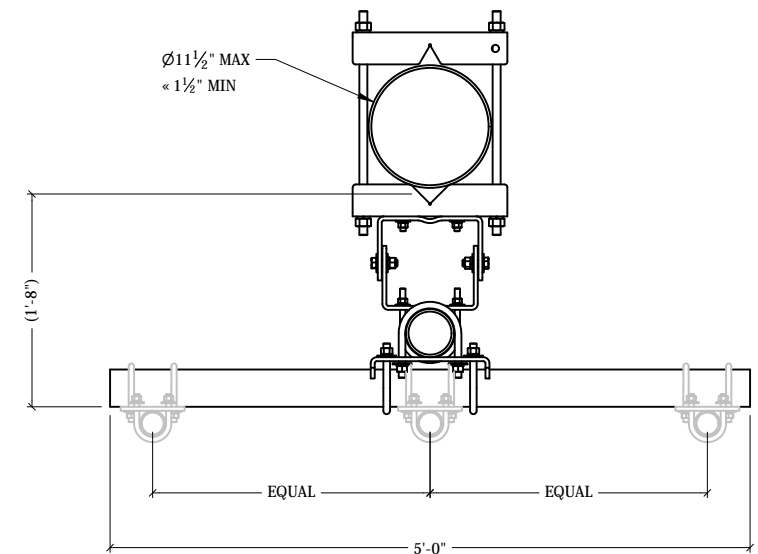

TOP VIEW

ITEM	PART #	QTY	DESCRIPTION	LENGTH	FINISH	UNIT WT
1	AM1028-8U.01	2	INNER ADJUSTABLE CHANNEL CLAMP WELDMENT		HDG	12.14
2	AM1028-8U.04	2	OUTER ADJUSTABLE CHANNEL CLAMP WELDMENT		HDG	13.17
3	AM1028-U.01	2	3/8" PLATE		HDG	12.19
4	AM1028-U.02	2	3/8" PLATE		HDG	12.61
5	AM1015-XP.01	2	3/8" PLATE		HDG	15.26
6	P45-60	1	4" STD PIPE	5'	HDG	54.01
7	P35-60	2	3" STD PIPE	5'	HDG	37.92
8	27-5579-005	4	3/4" x 21" B7 HDG ALL-THREAD	1'-9"		2.63
9	27-5490-005	8	3/4 HDG LOCK WASHER			0.04
10	27-5500-005	8	3/4 HDG HEAVY HEX NUT			0.21
11	27-4403-005	4	5/8" x 2" GR.5 HDG BOLT			0.27
12	27-5370-005	8	5/8 A36 HDG FLAT WASHER			0.08
13	27-5380-005	4	5/8 HDG LOCK WASHER			0.03
14	27-5391-005	4	5/8" HDG HEX NUT			0.08
15	27-4302-005	8	1/2" x 1 3/4" GR.5 HDG BOLT			0.15
16	27-5200-005	16	1/2 A36 HDG FLAT WASHER			0.04
17	27-5210-005	8	1/2 HDG LOCK WASHER			0.01
18	27-5222-005	8	1/2 HDG HEX NUT			0.04
19	27-6230-005	4	GALV. 5/8" x 4-5/8" x 6-1/2" U-BOLT ASSEMBLY			1.80
20	27-6200-005	4	GALV. 5/8" x 3-5/8" x 6" U-BOLT ASSEMBLY			1.66
21	27-6140-005	4	GALV. 1/2" x 4 5/8" x 6 1/2" U-BOLT ASSEMBLY			1.10

THIS DESIGN AND INFORMATION CONTAINED ON THIS PRINT IS THE PROPERTY OF VALLEY FAB CORPORATION. ANY REPRODUCTION, DUPLICATION OR TRANSFER OF THE PROPRIETARY CONTENT IS PROHIBITED WITHOUT WRITTEN PERMISSION.

**STANDARD TOLERANCES:**  
(UNLESS OTHERWISE NOTED)  
FRACTIONS - 1/16"  
DECIMALS - 0.01"  
ANGLES - 0.5°

**NEWAVE**  
TOWER COMPONENTS, 503-792-3739  
10910 PORTLAND RD. BROOKS, OR 97305

TOTAL WT: 295.75 LB  
QTY:  
FINISH: HDG  
JOB #:

TITLE: 1-SECTOR ANTENNA/RRU MOUNT, 5' DBL FACE  
FITS UP TO 11" O.D RND OR 8" X 90° ANG

SERIES: TOWER ANTENNA MOUNT SHEET: 1 OF 1

DRAWN BY: KY DATE: 11/20/2020 CHK'D BY: -  
DRAWING NO. AM2028-60-2