

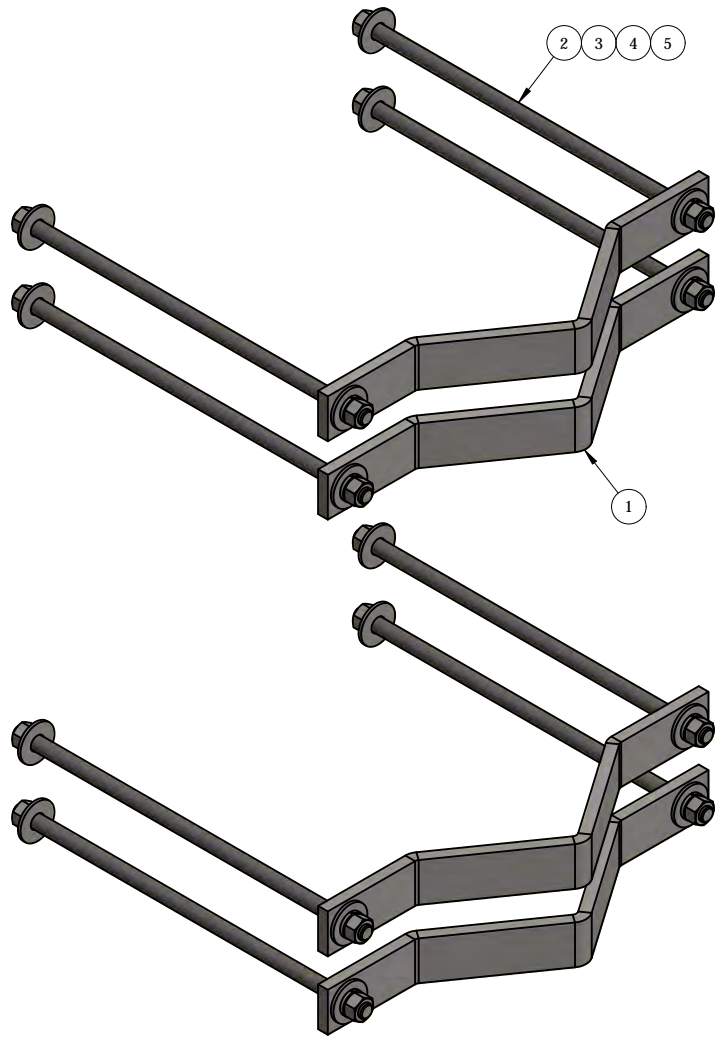

REV	BY	DESCRIPTION	DATE
A	KY	SEE MODEL IPROPERTIES/COMMENTS	9/10/2018



ITEM	PART #	QTY	DESCRIPTION	LENGTH	FINISH	UNIT WT
1	AMCS-16.01	4	1/2" PLATE		SEE W/O	5.99
2	TR58-18	8	5/8" x 18" A36 HDG ALL-THREAD	1'-6"		1.56
3	27-5370-005	16	5/8" A36 HDG FLAT WASHER			0.08
4	27-5380-005	16	5/8" HDG LOCK WASHER			0.03
5	27-5391-005	16	5/8" HDG HEX NUT			0.08

THIS DESIGN AND INFORMATION CONTAINED ON THIS PRINT IS THE PROPERTY OF VALLEY FAB CORPORATION. ANY REPRODUCTION, DUPLICATION OR TRANSFER OF THE PROPRIETARY CONTENT IS PROHIBITED WITHOUT WRITTEN PERMISSION.

STANDARD TOLERANCES:
 (UNLESS OTHERWISE NOTED)
 FRACTIONS - 1/16"
 DECIMALS - 0.01"
 ANGLES - 0.5°

NEWAVE
 TOWER COMPONENTS. 503-792-3739
 10910 PORTLAND RD. BROOKS, OR 97305

TOTAL WT: 39.45 LB
 QTY:
 FINISH: HDG
 JOB #:

TITLE: ANTENNA MOUNT HALF CLAMP KIT FOR 8" TO 16" OD ROUND			DRAWN BY: JG	DATE: 4/30/2019	CHK'D BY: KY
SERIES: TOWER ANTENNA MOUNTING			DRAWING NO. AMCS-16		
SHEET: 1 OF 1					