

REV	BY	DESCRIPTION	DATE
A	SJ	ADDED VERT ADJUSTMENT HOLES	3/13/2019

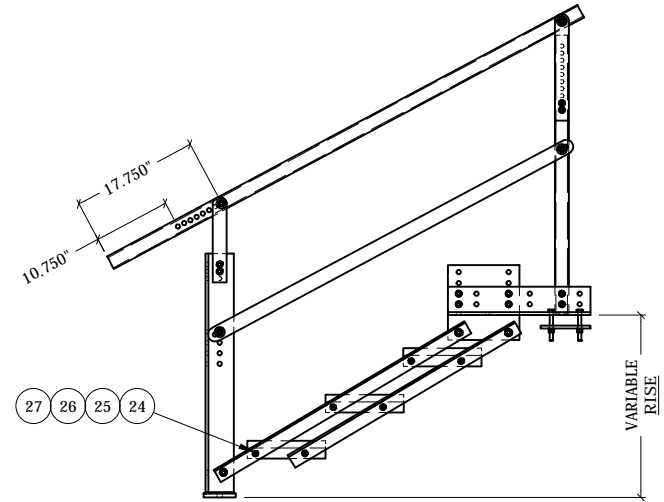
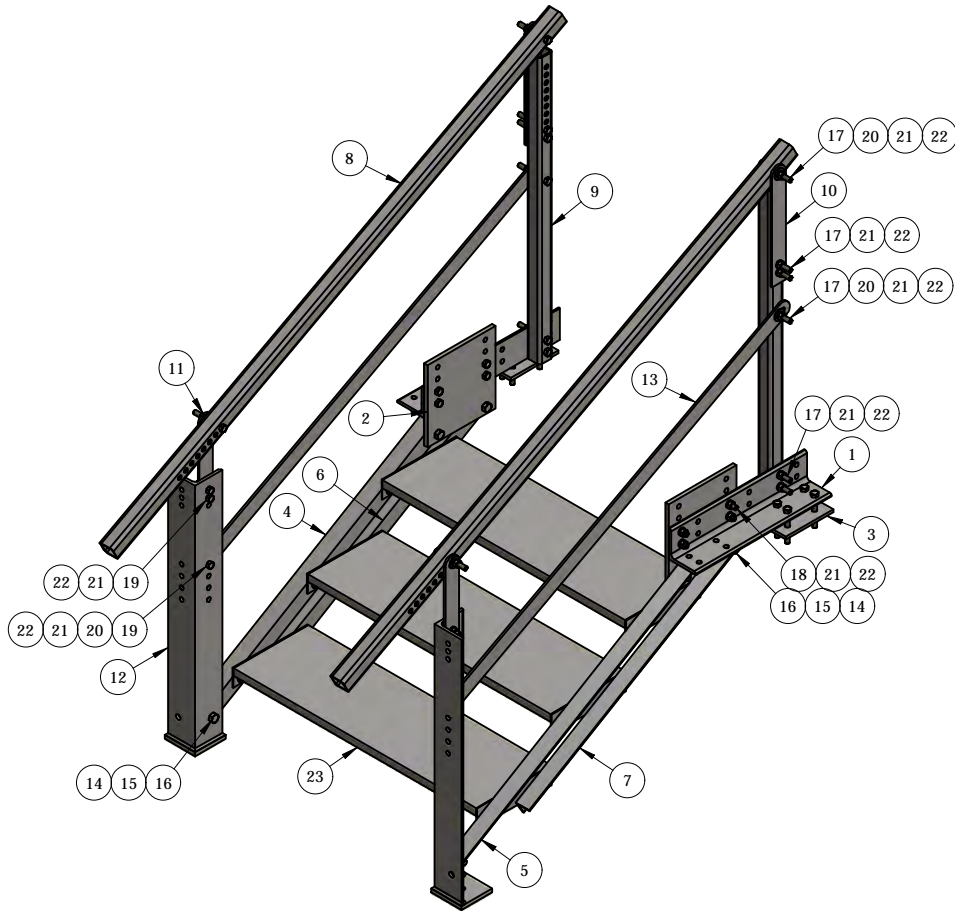

ITEM	PART #	QTY	DESCRIPTION	LENGTH	FINISH	UNIT WT
1	APS.01	2	L4"x4"x3/8" @ 1'-8" LONG	1'-8"	HDG	15.84
2	APS.02	2	1/2" PLATE		HDG	14.50
3	APS.03	2	3/8" PLATE		HDG	2.87
4	APS3-36.01	1	L2"x2"x1/4" @ 3'-5" LONG	3'-5"	HDG	10.90
5	APS3-36.02	1	L2"x2"x1/4" @ 3'-5" LONG	3'-5"	HDG	10.90
6	APS3-36.03	1	L2"x2"x1/4" @ 3'-1" LONG	3'-1"	HDG	9.85
7	APS3-36.04	1	L2"x2"x1/4" @ 3'-1" LONG	3'-1"	HDG	9.85
8	APS3-36.05	2	HSS 2"x2"x3/16" @ 6'-3" LONG	6'-3"	HDG	26.75
9	APS3-36.06	2	HSS 2"x2"x3/16" @ 3'-3 1/16" LONG	3'-3 1/16"	HDG	13.71
10	APS3-36.07	2	1/4" RAILING PLATE @ 1'-3" LONG		HDG	2.03
11	APS3-36.08	2	1/4" RAILING PLATE @ 1' LONG		HDG	1.60
12	APS3-36.09	2	LOWER POST WELDMENT		HDG	30.13
13	APS3-36.12	2	1/4" MID- RAIL PLATE		HDG	8.07
14	27-5391-005	6	5/8" HDG HEX NUT		HDG	0.08
15	27-5380-005	6	5/8" HDG LOCK WASHER		HDG	0.03
16	27-4403-005	6	5/8" x 2" GR.5 HDG BOLT			0.27
17	27-4310-005	22	GALV. 1/2" x 4" GR.5 FULL THREADED BOLT			0.27
18	27-4303-005	2	GALV. 1/2" x 2" GR.5 BOLT			0.16
19	27-4302-005	12	1/2" x 1 3/4" GR.5 HDG BOLT			0.15
20	27-5200-005	8	1/2" A36 HDG FLAT WASHER			0.04
21	27-5210-005	36	1/2" HDG LOCK WASHER			0.01
22	27-5222-005	36	1/2" HDG HEX NUT			0.04
23	APS1-36.01	3	11" x 1" x 3/16" STAIR TREAD @ 36" LONG			22.19
24	27-5060-005	12	GALV. 3/8" x 1-1/4" GR.5 BOLT			0.06
25	27-5020-005	12	3/8" HDG LOCK WASHER			0.01
26	27-5030-005	12	3/8" HDG HEX NUT			0.02
27	27-5010-005	12	GALV. 3/8" FLAT WASHER		HDG	0.02

THIS DESIGN AND INFORMATION CONTAINED ON THIS PRINT IS THE PROPERTY OF VALLEY FAB CORPORATION. ANY REPRODUCTION, DUPLICATION OR TRANSFER OF THE PROPRIETARY CONTENT IS PROHIBITED WITHOUT WRITTEN PERMISSION.

STANDARD TOLERANCES:

(UNLESS OTHERWISE NOTED)
 FRACTIONS - 1/16"
 DECIMALS - 0.01"
 ANGLES - 0.5°



TOWER COMPONENTS. 503-792-3739
 10910 PORTLAND RD. BROOKS, OR 97305

TOTAL WT: 353.05 LB

QTY:

FINISH: HDG

JOB #:

TITLE:

25-5/8" TO 37-11/16" RISE, 3' WIDE
 3-STEP ADJUSTABLE PLATFORM STAIRS

SERIES: PLATFORMS

SHEET: 1 OF 1

DRAWN BY: JG DATE: 5/23/2018 CHK'D BY:

DRAWING NO. APS3-36

HARDWARE & PURCHASE LIST

PART #	DESCRIPTION	GRADE	FINISH	QTY	UNIT WT
27-4403-005	5/8" x 2" GR.5 HDG BOLT			6	0.27
27-5380-005	5/8" HDG LOCK WASHER		HDG	6	0.03
27-5391-005	5/8" HDG HEX NUT		HDG	6	0.08
27-5222-005	1/2" HDG HEX NUT			36	0.04
27-5210-005	1/2" HDG LOCK WASHER			36	0.01
27-4303-005	GALV. 1/2" x 2" GR.5 BOLT			2	0.16
27-4310-005	GALV. 1/2" x 4" GR.5 FULL THREADED BOLT			22	0.27
27-4302-005	1/2" x 1 3/4" GR.5 HDG BOLT			12	0.15
27-5200-005	1/2" A36 HDG FLAT WASHER			8	0.04
27-5060-005	GALV. 3/8" x 1-1/4" GR.5 BOLT			12	0.06
27-5020-005	3/8" HDG LOCK WASHER			12	0.01
27-5030-005	3/8" HDG HEX NUT			12	0.02
27-5010-005	GALV. 3/8" FLAT WASHER		HDG	12	0.02



NEWAVE
 TOWER COMPONENTS. 503-792-3739
 10910 PORTLAND RD. BROOKS, OR 97305

THIS DESIGN AND INFORMATION CONTAINED ON THIS PRINT IS THE PROPERTY OF VALLEY FAB CORPORATION. ANY REPRODUCTION, DUPLICATION OR TRANSFER OF THE PROPRIETARY CONTENT IS PROHIBITED WITHOUT WRITTEN PERMISSION.

TITLE: 25-5/8" TO 37-11/16" RISE, 3' WIDE 3-STEP ADJUSTABLE PLATFORM STAIRS	DRAWN BY: JG	DATE: 10/19/2018	CHK'D BY:
SERIES: PLATFORMS	JOB #: 70169	DRAWING NO. APS3-36	

MAIN PART SHIPPING LIST

PART #	DESCRIPTION	LENGTH	QTY	FINISH	UNIT WT	SHIP'D	RECV'D
APS1-36.01	11" x 1" x 3/16" STAIR TREAD @ 36" LONG		3		22.19		
APS3-36.01	L2"x2"x1/4" @ 3'-5" LONG	3'-5"	1	HDG	10.90		
APS3-36.02	L2"x2"x1/4" @ 3'-5" LONG	3'-5"	1	HDG	10.90		
APS3-36.03	L2"x2"x1/4" @ 3'-1" LONG	3'-1"	1	HDG	9.85		
APS3-36.04	L2"x2"x1/4" @ 3'-1" LONG	3'-1"	1	HDG	9.85		
APS3-36.05	HSS 2"x2"x3/16" @ 6'-3" LONG	6'-3"	2	HDG	26.75		
APS3-36.06	HSS 2"x2"x3/16" @ 3'-3 1/16" LONG	3'-3 1/16"	2	HDG	13.71		
APS3-36.07	1/4" RAILING PLATE @ 1'-3" LONG		2	HDG	2.03		
APS3-36.08	1/4" RAILING PLATE @ 1' LONG		2	HDG	1.60		
APS3-36.09	LOWER POST WELDMENT		2	HDG	30.13		
APS3-36.12	1/4" MID- RAIL PLATE		2	HDG	8.07		
APS.01	L4"x4"x3/8" @ 1'-8" LONG	1'-8"	2	HDG	15.84		
APS.02	1/2" PLATE		2	HDG	14.50		
APS.03	3/8" PLATE		2	HDG	2.87		



NEWAVE
 TOWER COMPONENTS. 503-792-3739
 10910 PORTLAND RD. BROOKS, OR 97305

THIS DESIGN AND INFORMATION CONTAINED ON THIS PRINT IS THE PROPERTY OF VALLEY FAB CORPORATION. ANY REPRODUCTION, DUPLICATION OR TRANSFER OF THE PROPRIETARY CONTENT IS PROHIBITED WITHOUT WRITTEN PERMISSION.

TITLE:	25-5/8" TO 37-11/16" RISE, 3' WIDE 3-STEP ADJUSTABLE PLATFORM STAIRS	DRAWN BY:	JG	DATE:	10/19/2018	CHK'D BY:	
SERIES:	PLATFORMS	JOB #:	70169	DRAWING NO. APS3-36			