

NOTE: IF THE PIPE SIZE IS 6<sup>5</sup>/<sub>8</sub>" O.D AND UNDER  
 PROVIDE 12" ALTHREAD INSTEAD OF 14" ALL-THREAD!

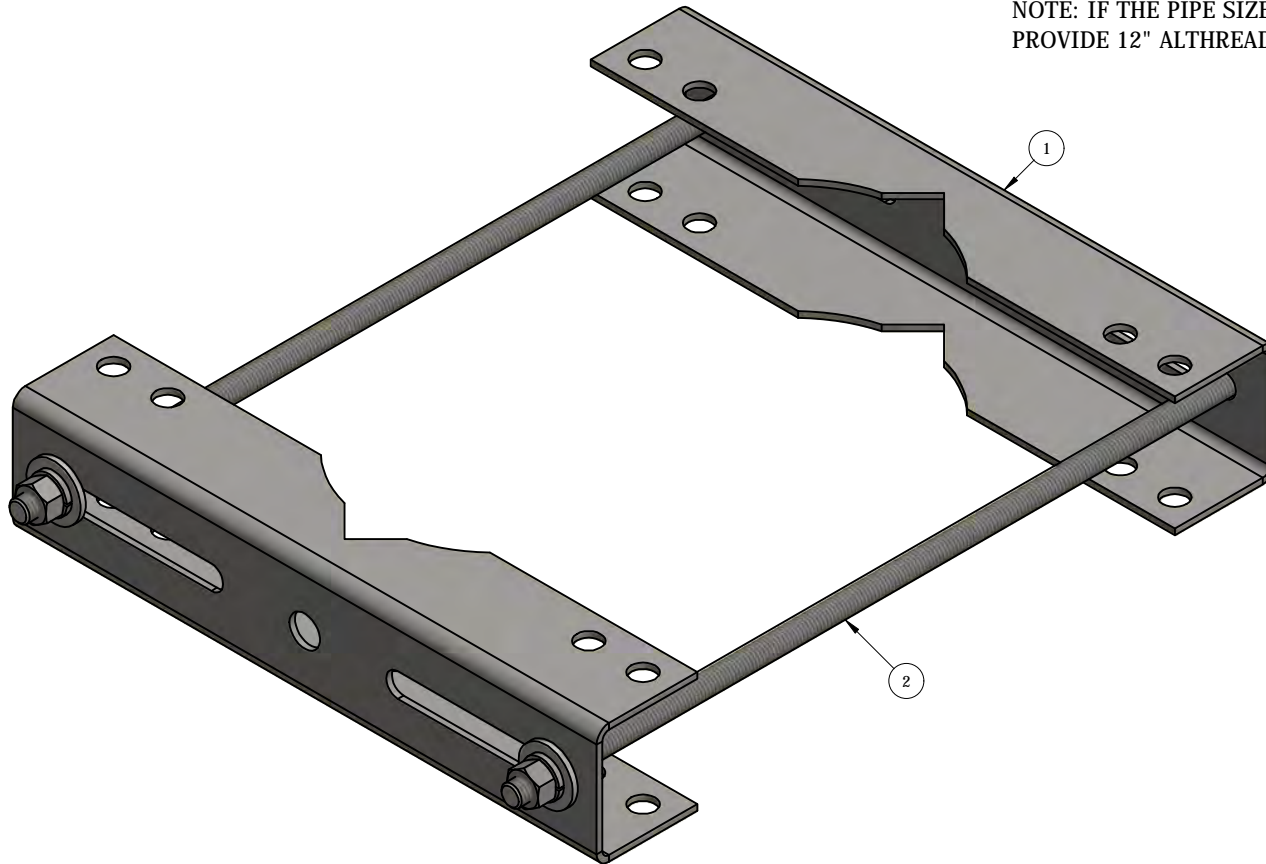

ITEM	PART #	QTY	DESCRIPTION	LENGTH	FINISH	UNIT WT
1	CA2000-8.01	2	12 GA SHEET METAL		HDG	1.55
2	TR38-14	2	GALV. 3/8" x 14" ALL-THREAD			0.44
3	27-5010-005	4	GALV. 3/8" FLAT WASHER		HDG	0.02
4	27-5020-005	4	3/8" HDG LOCK WASHER			0.01
5	27-5030-005	4	3/8" HDG HEX NUT			0.02

THIS DESIGN AND INFORMATION CONTAINED ON THIS PRINT IS THE PROPERTY OF VALLEY FAB CORPORATION. ANY REPRODUCTION, DUPLICATION OR TRANSFER OF THE PROPRIETARY CONTENT IS PROHIBITED WITHOUT WRITTEN PERMISSION.

**STANDARD TOLERANCES:**

(UNLESS OTHERWISE NOTED)  
 FRACTIONS - 1/16"  
 DECIMALS - 0.01"  
 ANGLES - 0.5°

  
**NEWAVE**  
 TOWER COMPONENTS. 503-792-3739  
 10910 PORTLAND RD. BROOKS, OR 97305

TOTAL WT: 4.15 LB

QTY:

FINISH: HDG

JOB #:

TITLE: <b>UNIVERSAL CLAMP MOUNT FOR 1-1/2" TO 8-5/8" ROUND OR UP TO 6" ANGLE</b>			DRAWN BY: <b>JG</b>	DATE: <b>7/17/2018</b>	CHK'D BY:
SERIES: COAX SUPPORT			DRAWING NO. <b>CA2000-8</b>		
SHEET: 1 OF 1					