

SIDE VIEW

ITEM	PART #	DESCRIPTION	QTY	UNIT WT
1	M1060-4.01	4-SECTOR UNIVERSAL 10" x 59" O.D. RING MOUNT WELDMENT	4	27.96
2	27-5588-005	GALV. 3/4" B7 ALL THREAD @ 42" LONG	8	5.25
3	27-5490-005	GALV. 3/4" LOCK WASHER	16	0.05
4	27-5481-005	GALV. 3/4" FLAT WASHER	16	0.09
5	27-5501-005	GALV. 3/4" HEX NUT REGULAR	16	0.14
6	LPS.01	LOWER MOUNTING BRACKET	4	9.86
7	LPS30-20.01	LOW PROFILE TOP BRACKET WELDMENT	4	6.69
8	LPS.05	GALV. L3"x3"x1/4" ANGLE STIFFENER @ 10' LONG	8	49.24
9	LPCP.01	1/2" CLAMP PLATE	8	1.81
10	TR58-12	GALV. 5/8" x 12" ALL-THREAD	16	1.04
11	27-4404-005	GALV. 5/8" x 2-1/4" GR.5 BOLT	16	0.29
12	27-4403-005	GALV. 5/8" x 2" GR.5 BOLT	8	0.27
13	27-5370-005	GALV. 5/8" FLAT WASHER	32	0.07
14	27-5380-005	GALV. 5/8" LOCK WASHER	56	0.03
15	27-5391-005	GALV. 5/8" HEX NUT	56	0.08

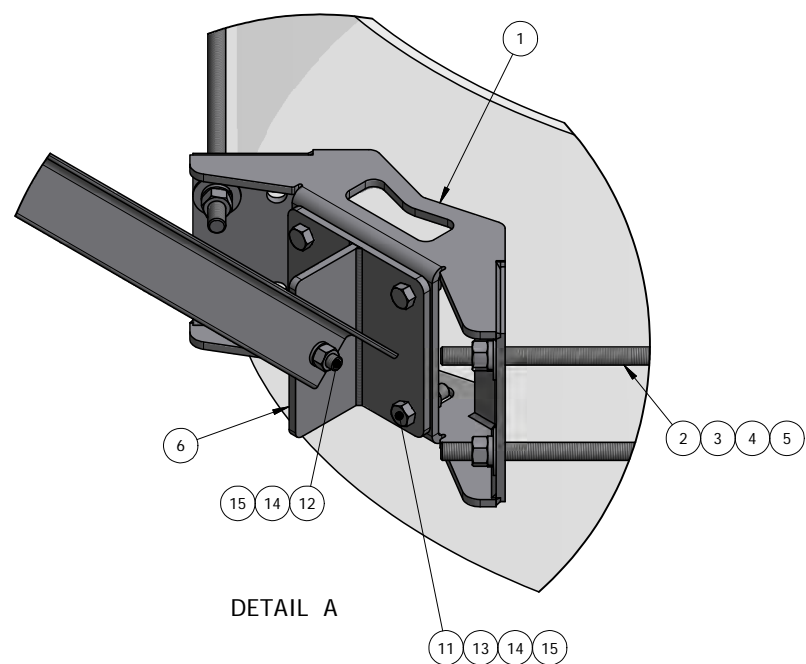
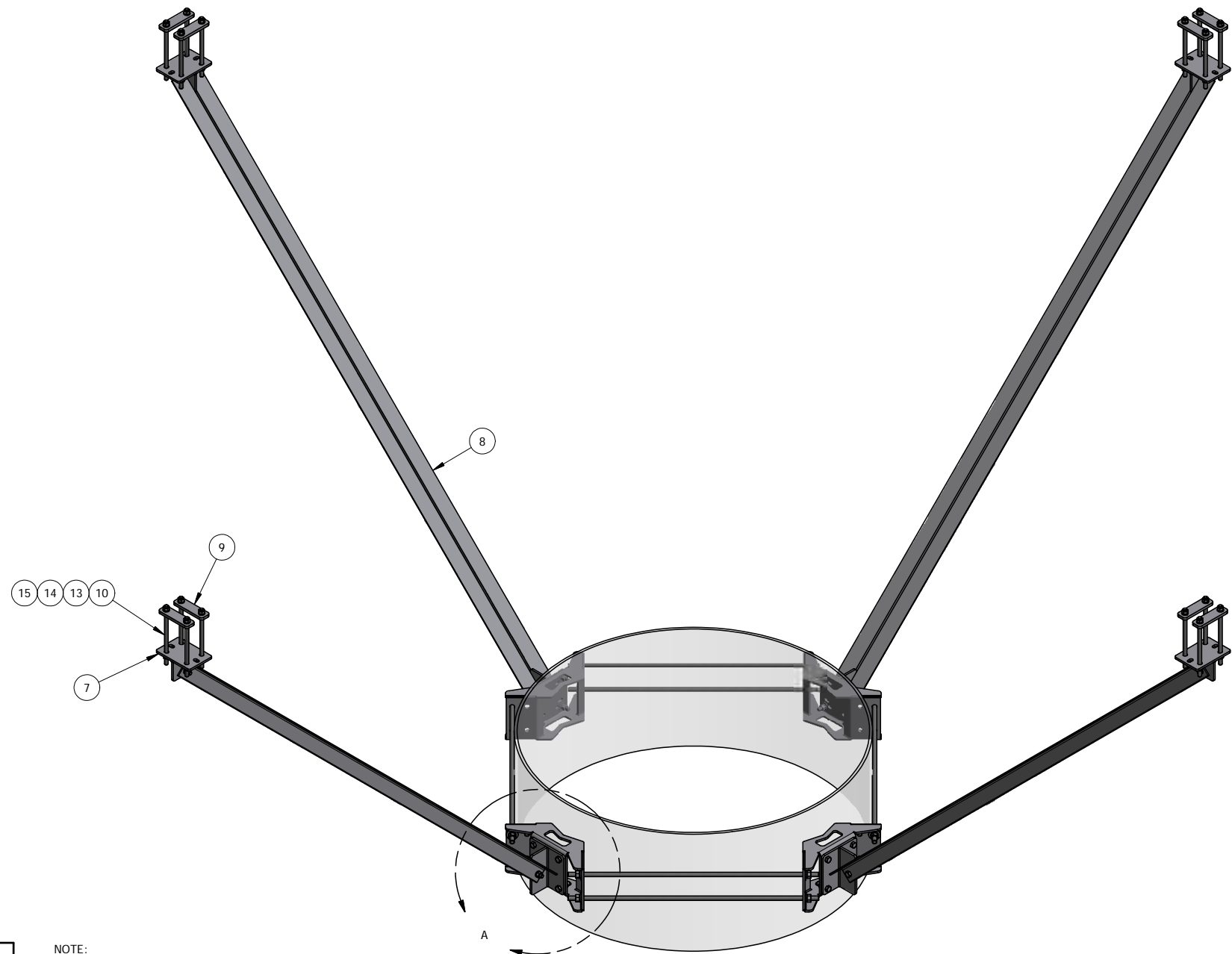

DETAIL A

QTY:  
CHK:

NOTE:  
1. FIELD CUT ANGLE AND DRILL HOLE  
2. FIELD CUT ALL THREAD

**STANDARD TOLERANCES:**  
(UNLESS OTHERWISE NOTED)  
FRACTIONS ±1/16"  
DECIMALS ±.005"  
ANGLES ±.5°

THIS DESIGN AND INFORMATION CONTAINED ON THIS PRINT IS THE PROPERTY OF NEWAVE TOWER COMPONENTS LLC. ANY REPRODUCTION, DUPLICATION OR TRANSFER OF THE PROPRIETARY CONTENT IS PROHIBITED WITHOUT WRITTEN PERMISSION.

**NEWAVE**  
Tower Components, 503-792-3739  
10910 PORTLAND RD. BROOKS, OR 97305

MATERIAL: AS SHOWN  
HOLES: AS SHOWN  
FINISH: HDG

DRAWN BY: JG  
CHECKED BY: CJW  
DATE: 12/1/2015

TITLE: 4-SECTOR LOW PROFILE CO-LOCATION STIFFENER W/ 10" TO 59" RING MOUNT  
SERIES: MONOPOLE MOUNTING  
PART WT (BARE): 664.9 LB  
DRAWING NO. LPS40-25  
SHEET: 1 OF 1