

ITEM	PART #	DESCRIPTION	QTY	UNIT WT
1	MCMX-SA.01	UNIVERSAL CHAIN MOUNT BRACKET WELDMENT	1	6.05
2	35- G14CG43	GALV. 1/4" HIGH TINSEL STRENGTH CHAIN @ 10'-0" LONG	1	0.36
3	MCMX.04	CHAIN MOUNT CLEVIS BOLT ATTACHEMT WELDMENT	2	1.40
4	27-5340-005	1/2" x 6" CLEVIS BOLT - RH OR LH THREAD	2	0.47
5	27-4206-005	GALV. 3/8" x 2-1/4" GR.5 BOLT	2	0.09
6	27-5020-005	GALV. 3/8" LOCK WASHER	2	0.01
7	27-5030-005	GALV. 3/8" HEX NUT	2	0.02
8	27-5210-005	GALV. 1/2" LOCK WASHER	2	0.01
9	27-5222-005	GALV. 1/2" HEX NUT (MATCH THREAD TO CLEVIS BOLT)	4	0.04
10	MCMX-SA.03	1/4" BENT STIFF ARM ATTACHMENT ANGLE	2	16.66
11	MCMX-SA.04	STIFF ARM CHAIN MOUNT BRACKET WELDMENT W/ U-BARS	1	7.59
12	27-4403-005	GALV. 5/8" x 2" GR.5 BOLT	4	0.27
13	27-5380-005	GALV. 5/8" LOCK WASHER	4	0.03
14	27-5391-005	GALV. 5/8" HEX NUT	4	0.08

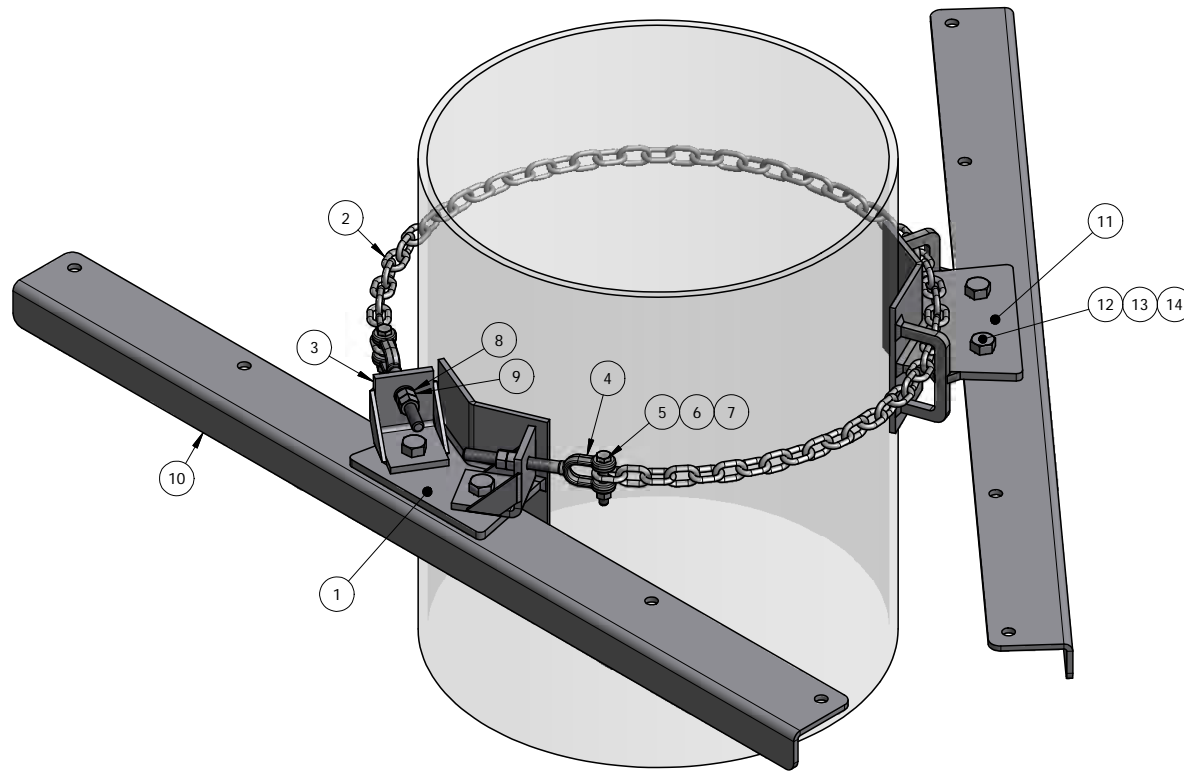

QTY:  
CHK:

**STANDARD TOLERANCES:**  
(UNLESS OTHERWISE NOTED)  
FRACTIONS ± 1/16"  
DECIMALS ± .005"  
ANGLES ± .5°

THIS DESIGN AND INFORMATION CONTAINED ON THIS PRINT IS THE PROPERTY OF NEWAVE TOWER COMPONENTS LLC. ANY REPRODUCTION, DUPLICATION OR TRANSFER OF THE PROPRIETARY CONTENT IS PROHIBITED WITHOUT WRITTEN PERMISSION.

**NEWAVE**  
Tower Components. 503-792-3739  
10910 PORTLAND RD. BROOKS, OR 97305

MATERIAL: AS SHOWN  
HOLES: AS SHOWN  
FINISH: HDG  
DRAWN BY: KY  
CHECKED BY:  
DATE: 1/7/2013

TITLE: CHAIN MOUNT FOR DOUBLE SIFFF ARM SINGLE CHAIN CONNECTION  
SERIES: MONOPOLE MOUNTING  
PART WT (BARE): 53.0 LB  
DRAWING NO. MCMX-SAD  
SHEET: 1 OF 1