

REV	BY	DESCRIPTION	DATE
A	KY	SEE MODEL I PROPERTIES/ COMMENTS	9/10/2018

ITEM	PART #	DESCRIPTION	QTY	UNIT WT
1	MDS-36-16.01	3/8" PLATE	1	32.34
2	AMCS-16.01	1/2" PLATE	2	5.99
3	25-TR58-18	GALV. 5/8" x 18" ALL-THREAD	4	1.56
4	27-5370-005	5/8" A36 HDG FLAT WASHER	8	0.08
5	27-5380-005	5/8 HDG LOCK WASHER	8	0.03
6	27-5391-005	5/8" HDG HEX NUT	8	0.08
7	P35-72	3" STD PIPE	1	45.50
8	27-6190-005	GALV. 5/8" x 3-5/8" x 5" U-BOLT ASSEMBLY	2	1.49

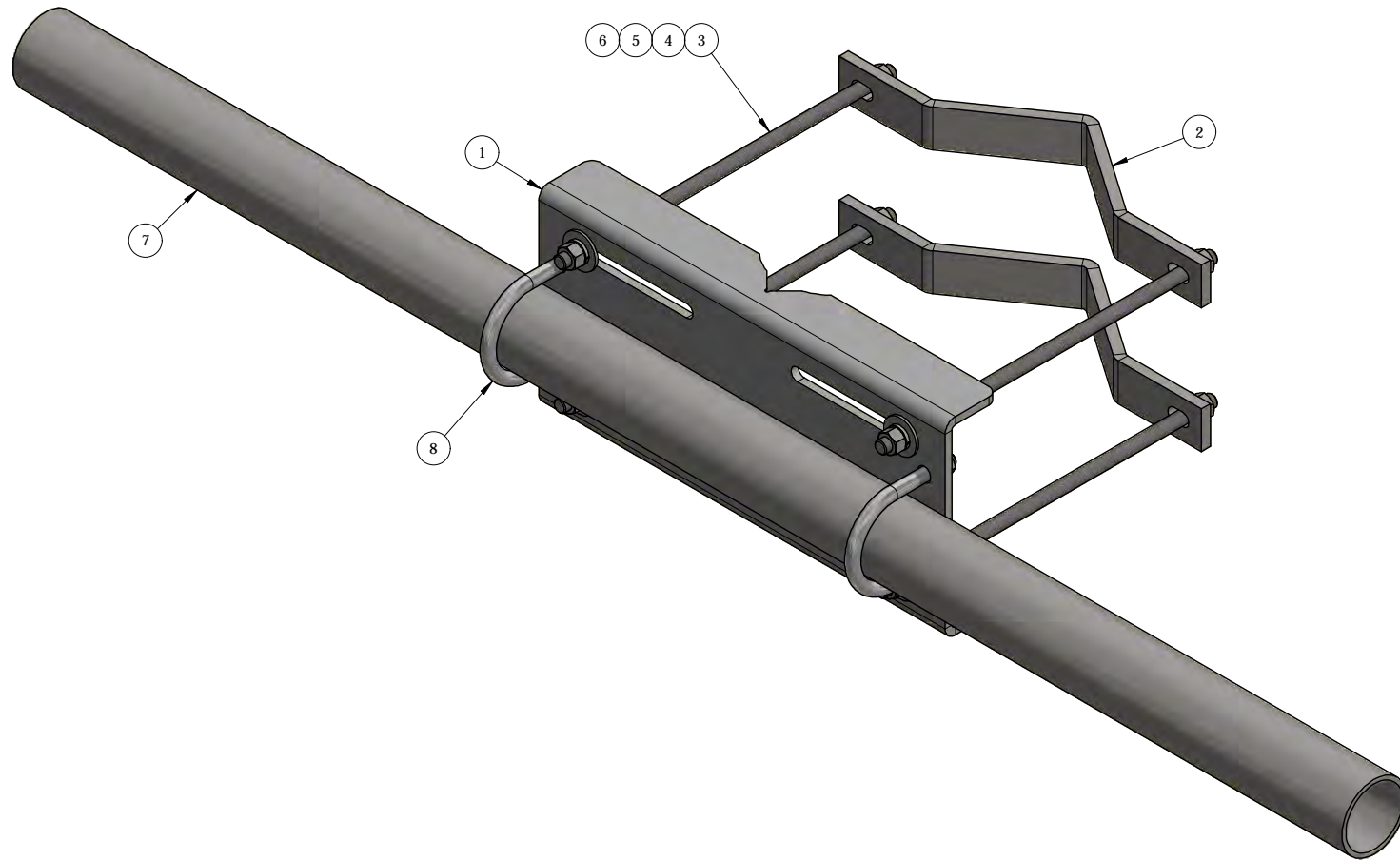

QTY:
CHK:

STANDARD TOLERANCES:
(UNLESS OTHERWISE NOTED)
FRACTIONS - 1/16"
DECIMALS - .005"
ANGLES - .5°

THIS DESIGN AND INFORMATION
CONTAINED ON THIS PRINT IS THE
PROPERTY OF VALLEY FAB CORP. ANY
REPRODUCTION, DUPLICATION OR
TRANSFER OF THE PROPRIETARY CONTENT
IS PROHIBITED WITHOUT
WRITTEN PERMISSION.

VALLEY FAB
CORP
10910 PORTLAND RD. BROOKS, OR 97305
PH(503)792-3739 FAX(503)792-3738

MATERIAL: AS SHOWN
HOLES: AS SHOWN
FINISH: HDG
DRAWN BY: JG
CHECKED BY:
DATE: 8/3/2015

TITLE: MICROWAVE DISH CHANNEL SUPPORT
MOUNTS UP TO 16" O.D TOWER LEG
SERIES: TOWER ANTENNA MOUNT
PART WT (BARE): 101 LB
DRAWING NO. MDS-36-16
SHEET 1 : 1