

DETAIL A

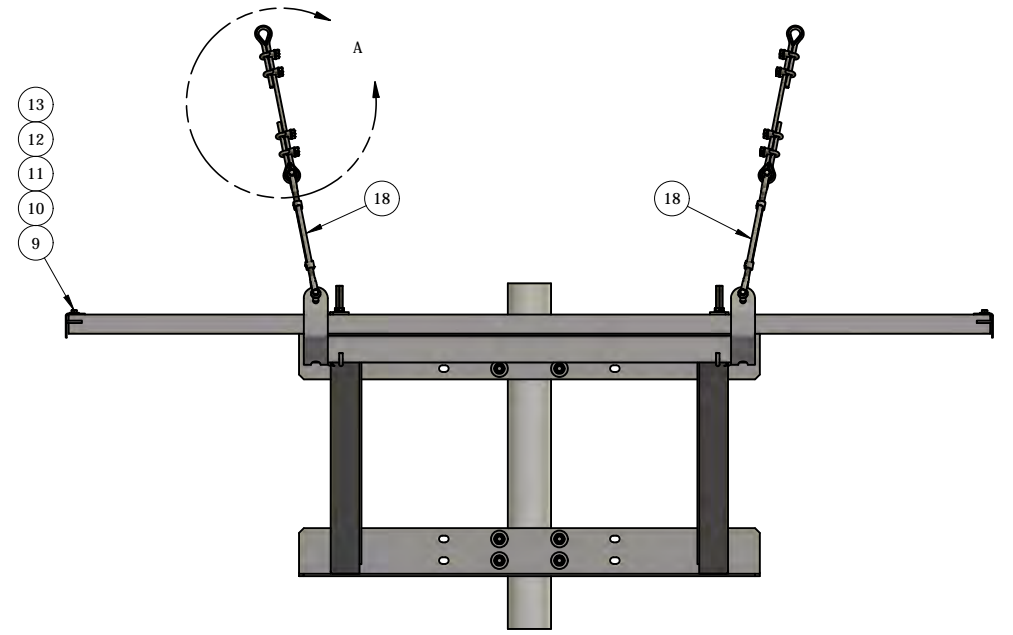

FRONT VIEW

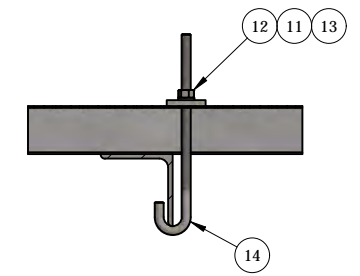

J-BOLT CONNECTION DETAIL

ITEM	PART #	QTY	DESCRIPTION	LENGTH	FINISH	UNIT WT
1	MIS8.01	1	MICRO. ICE SHIELD FRAME 4'-0" WIDE x 5'-2-1/2"		HDG	172.29
2	MIS8.09	3	1'-6 3/4" x 2" x 14 GA GRIP STRUT	8'	G90	54.66
3	MIS8.10	2	12 GA SHEET METAL		HDG	7.19
4	AMCS-5.01	4	1/2" PLATE		SEE W/O	2.25
5	TR58-8	8	5/8" x 8" A36 HDG ALL-THREAD	8"		0.69
6	27-5370-005	16	5/8 A36 HDG FLAT WASHER			0.08
7	27-5380-005	16	5/8 HDG LOCK WASHER			0.03
8	27-5391-005	16	5/8" HDG HEX NUT			0.08
9	27-4204-005	12	3/8" x 1 3/4" GR.5 HDG BOLT			0.08
10	27-5010-005	12	3/8 A36 HDG FLAT WASHER			0.01
11	27-5020-005	24	3/8 HDG LOCK WASHER			0.01
12	27-5030-005	24	3/8" HDG HEX NUT			0.02
13	SFW-716G	24	1/4" PLATE		HDG	0.18
14	27-5190-005	12	GALV. 3/8" x 8" J-BOLT W/ 3/4" SPACING			0.31
15	35- CABLE38-25	2	GALV. - < 3/8" CABLE, 7X19 STRAND @ 25'-0"			7.50
16	35- THIMBLE38	4	GALV - 3/8" HD WIRE ROPE THIMBLE			0.03
17	35- ROPECLIP38	8	GALV - 3/8" DROP FORGED WIRE ROPE CLIP			0.25
18	27- TB126	2	GALV - 1/2" x 6" TURN BUCKLE, JAW/JAW			1.72

THIS DESIGN AND INFORMATION CONTAINED ON THIS PRINT IS THE PROPERTY OF VALLEY FAB CORPORATION. ANY REPRODUCTION, DUPLICATION OR TRANSFER OF THE PROPRIETARY CONTENT IS PROHIBITED WITHOUT WRITTEN PERMISSION.

STANDARD TOLERANCES:
 (UNLESS OTHERWISE NOTED)
 FRACTIONS - 1/16"
 DECIMALS - 0.01"
 ANGLES - 0.5°

NEWAVE
 TOWER COMPONENTS, 503-792-3739
 10910 PORTLAND RD. BROOKS, OR 97305

TOTAL WT: 398.45 LB
 QTY:
 FINISH: HDG
 JOB #:

TITLE: MICROWAVE ICE SHIELD
 8'-0" x 5'-2-1/2" DEEP (FLAT)

SERIES: MICROWAVE ICE SHIELD SHEET: 1 OF 1

DRAWN BY: KY DATE: 7/17/2018 CHK'D BY: KY
 DRAWING NO. MIS8