

SIDE VIEW

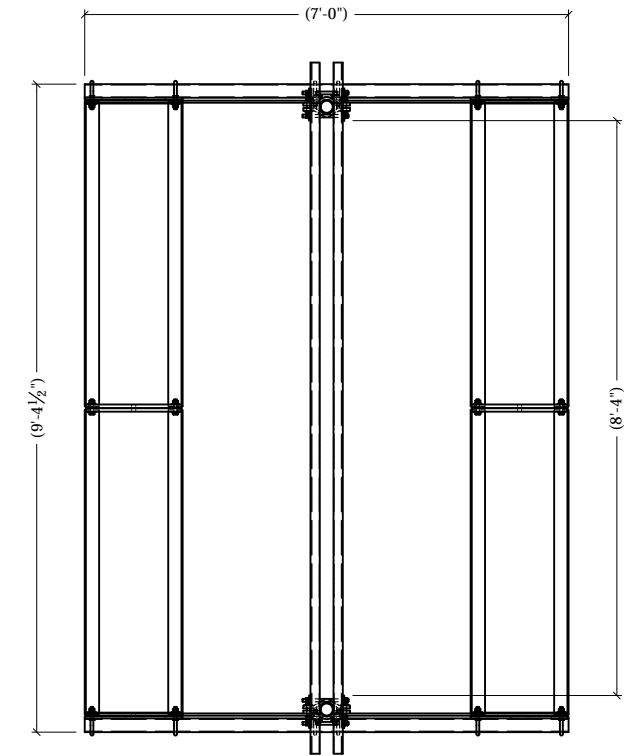

TOP VIEW

ITEM	PART #	QTY	DESCRIPTION	LENGTH	FINISH	UNIT WT
1	RT-RRU10.01	4	3/8" PLATE		HDG	10.48
2	RT-RRU5.01	4	ROOFTOP NON-PENETRATING TRAY WELDMENT		HDG	38.62
3	US10G	4	1 5/8" P1000T @ 10' LONG	10'	HDG	16.24
4	RTNP-PF.01	4	3/8" PLATE		HDG	9.70
5	CXP1	2	3/8" PLATE		SEE W/O	4.81
6	AMCS-5.01	4	1/2" PLATE		SEE W/O	2.25
7	SFW-916G	16	1/4" PLATE		HDG	0.17
8	P23-84	2	2" STD PIPE	7'	HDG	25.60
9	P23-72	2	2" STD PIPE	6'	HDG	21.94
10	TR12-8	8	1/2" x 8" A36 HDG ALL-THREAD	8"		0.44
11	27-4307-005	4	1/2" x 3" GR.5 HDG BOLT			0.22
12	27-4304-005	4	1/2" x 2 1/4" GR.5 HDG BOLT			0.18
13	27-4303-005	8	1/2" x 2" GR.5 HDG BOLT			0.16
14	27-5200-005	20	1/2 A36 HDG FLAT WASHER			0.04
15	27-5210-005	32	1/2 HDG LOCK WASHER			0.01
16	27-5222-005	32	1/2 HDG HEX NUT			0.04
17	27-6060-005	16	GALV. 1/2" x 2-1/2" x 4" GR-5 U-BOLT ASSEMBLY			0.76

THIS DESIGN AND INFORMATION CONTAINED ON THIS PRINT IS THE PROPERTY OF VALLEY FAB CORPORATION. ANY REPRODUCTION, DUPLICATION OR TRANSFER OF THE PROPRIETARY CONTENT IS PROHIBITED WITHOUT WRITTEN PERMISSION.

STANDARD TOLERANCES:
(UNLESS OTHERWISE NOTED)
FRACTIONS - 1/16"
DECIMALS - 0.01"
ANGLES - 0.5°

NEWAVE
TOWER COMPONENTS, 503-792-3739
10910 PORTLAND RD. BROOKS, OR 97305

TOTAL WT: 437.75 LB
QTY:
FINISH:
JOB #:

TITLE: 10' FACE ROOFTOP RRU MOUNT

SERIES: ROOFTOP MOUNTING SHEET: 1 OF 1

DRAWN BY: JG DATE: 7/17/2018 CHK'D BY: CJW

DRAWING NO. RT-RRU10