

REV	BY	DESCRIPTION	DATE
A	KY	SEE MODEL I PROPERTIES/COMMENTS	8/17/2021

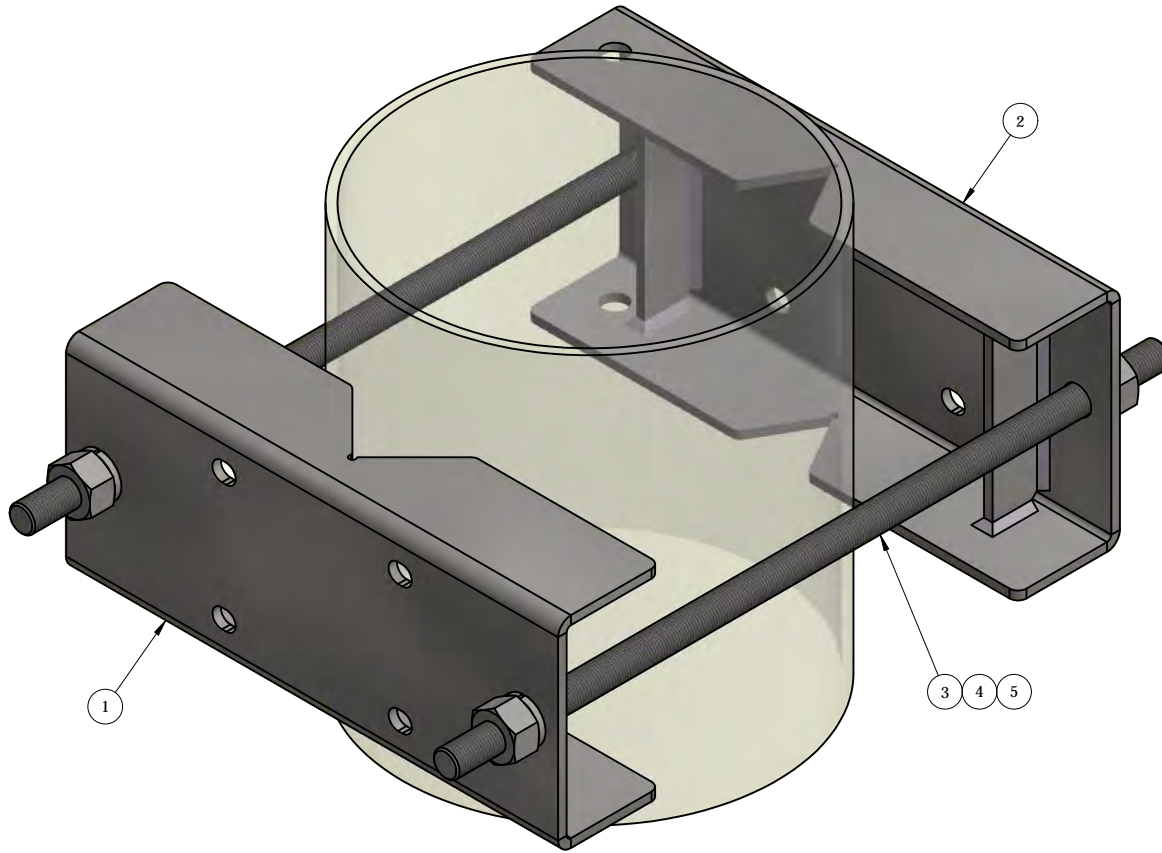

ITEM	PART #	QTY	DESCRIPTION	LENGTH	FINISH	UNIT WT
1	AM1028-8U.01	1	INNER ADJUSTABLE CHANNEL CLAMP WELDMENT		HDG	12.14
2	AM1028-8U.04	1	OUTER ADJUSTABLE CHANNEL CLAMP WELDMENT		HDG	13.17
3	27-5579-005	2	3/4" x 21" B7 HDG ALL-THREAD	1'-9"		2.63
4	27-5490-005	4	3/4 HDG LOCK WASHER			0.04
5	27-5500-005	4	3/4 HDG HEAVY HEX NUT			0.21

THIS DESIGN AND INFORMATION CONTAINED ON THIS PRINT IS THE PROPERTY OF VALLEY FAB CORPORATION. ANY REPRODUCTION, DUPLICATION OR TRANSFER OF THE PROPRIETARY CONTENT IS PROHIBITED WITHOUT WRITTEN PERMISSION.

**STANDARD TOLERANCES:**

(UNLESS OTHERWISE NOTED)  
 FRACTIONS - 1/16"  
 DECIMALS - 0.01"  
 ANGLES - 0.5°

**NEWAVE**  
 TOWER COMPONENTS. 503-792-3739  
 10910 PORTLAND RD. BROOKS, OR 97305

TOTAL WT: 31.6 LB

QTY:

FINISH:

JOB #:

TITLE:

**TIE-BACK MOUNT, FITS UP TO  
11" O.D ROUND OR 8" X 90° ANGLE LEG**

SERIES: TOWER ANTENNA MOUNT

SHEET: 1 OF 1

DRAWN BY:

JG

DATE:

7/17/2018

CHK'D BY:

KY

DRAWING NO.

TB11