

REV	BY	DESCRIPTION	DATE
A	KY	SEE MODEL IPROPERTIES/ COMMENTS	8/17/2021

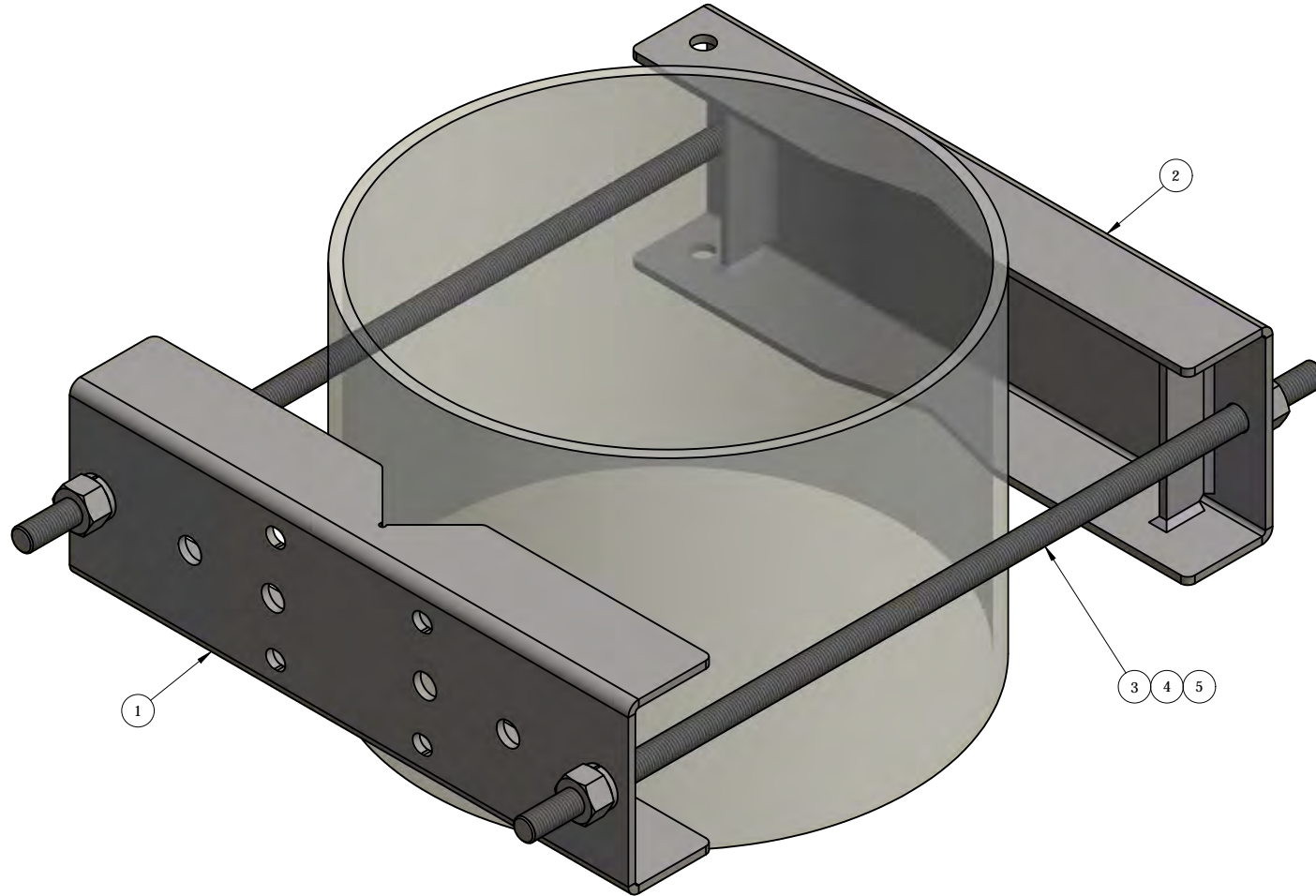

ITEM	PART #	QTY	DESCRIPTION	LENGTH	FINISH	UNIT WT
1	AM1028-17U.01	1	INSIDE ADJUSTABLE 17" CHANNEL CLAMP WLM'T		HDG	16.07
2	AM1028-17U.03	1	OUTSIDE ADJUSTABLE 17" CHANNEL CLAMP WLM'T		HDG	17.54
3	27-5580-005	2	3/4" x 28" B7 HDG ALL-THREAD	2'-4"		3.51
4	27-5490-005	4	3/4 HDG LOCK WASHER			0.04
5	27-5500-005	4	3/4 HDG HEAVY HEX NUT			0.21

THIS DESIGN AND INFORMATION CONTAINED ON THIS PRINT IS THE PROPERTY OF VALLEY FAB CORPORATION. ANY REPRODUCTION, DUPLICATION OR TRANSFER OF THE PROPRIETARY CONTENT IS PROHIBITED WITHOUT WRITTEN PERMISSION.

STANDARD TOLERANCES:

(UNLESS OTHERWISE NOTED)

FRACTIONS - 1/16"
 DECIMALS - 0.01"
 ANGLES - 0.5°



TOTAL WT: 41.65 LB

QTY:

FINISH:

JOB #:

TITLE:

TIE-BACK MOUNT, FITS UP TO
 17" O.D ROUND OR 12" X 90° ANGLE LEG

SERIES: TOWER ANTENNA MOUNT

SHEET: 1 OF 1

DRAWN BY:

JG

DATE:

7/17/2018

CHK'D BY:

KY

DRAWING NO.

TB17